

GRINDING

MORTAR GRINDER RM 100



GRINDING

RETSCH mortar grinders are extremely universal. They are particularly suited to ultra-fine grinding of inorganic and organic substances for analysis purposes.

MIXING

RETSCH mortar grinders mix and homogenize powders, suspensions and pastes.

TRITURATION

RETSCH mortar grinders are ideal for the even trituration of homeopathic and pharmaceutical products.

ADVANTAGES

- simple operation
- no-loss preparation
- dry and wet grinding
- free of interfering contamination with 7 different grinding sets
- reproducible results due to grinding pressure setting via scale and timer dial
- noise-damping grinding housing
- high-performance drive with overload switch
- user-friendly
- safe design according to CE standards
- 2 year warranty

Features

application	grinding, mixing, trituration, dry and wet
feed stock	soft, hard, brittle, pasty
feed size	< 8 mm
final fineness	< 10 µm
sample volume	max. 150 ml

Retsch

MORTAR GRINDER RM 100



RETSCH mortar grinders will grind, mix and triturate soft, hard, brittle and pasty materials with a hardness of up to 9 on the Mohs scale. They can provide fast and safe handling of ash, clays, chemicals, drugs, spices, resins, foodstuffs, pharmaceutical and homeopathic raw and finished materials, salts, oil seeds, slags, soils, silicates and cement clinker, and many more substances.

The maximum feed size of the products is approx. 8 mm, depending on the nature of the material. With a useful volume of 10 - 150 ml, final particle sizes of down to $< 10 \mu\text{m}$ are possible. Mortar grinders RM 100 are dust-proof, sealed grinding systems and can be used for dry and wet grinding. A wide selection of grinding sets in different materials (agate, hard porcelain, sintered corundum, chrome steel, stainless steel, tungsten carbide and zirconia) allows a sample preparation neutral to the following analysis. The scraper is made of wear-resistant Vulkulan as standard; a special version of beech is available on request, e.g. for the pharmaceutical sector acc. to DAB.

The grinding pressure can be set simply, steplessly and reproducibly via a scale. The opening cover of the grinding compartment is fitted with a mortar seal. Through the two Plexiglas windows in the cover, the grinding operation can be observed and feed material or additives (e.g. liquids) can be introduced during operation.



The grinder has an on/off switch and a timer dial with preselected time from 0 to 60 mins or continuous operation. RETSCH mortar grinders are suitable for the reproducible preparation of samples for analytical purposes as part of quality assurance and GLP, and in R+D applications.

MODERN DESIGN, EASY TO USE, QUIET

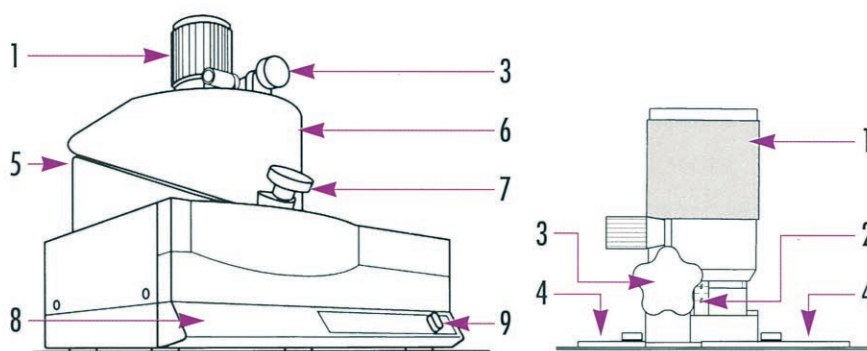

FEATURES OF THE RM 100

1. Pestle pressure adjustment
2. Scale for pressure setting
3. Scraper pressure setting
4. Plexiglas window
5. Safety switch for cover
6. Grinding compartment cover
7. Grinding compartment seal
8. Ergonomic control panel
9. Timer

SELECTION OF GRINDING SETS

A suitable grinding set material is selected primarily according to the degree of hardness of the material being ground and the possible influence from abrasion in the subsequent analysis or, as the case may be, further processing.

When handling hard, abrasive materials, in extended tests and for heavy metal-free preparation, we recommend the use of grinding sets made of agate, zirconia or tungsten carbide.

For less demanding applications and for rough operation, steel sets should be used.

For soft, medium-hard or pasty materials, grinding sets of hard porcelain or sintered corundum are, in most cases, adequate.



MATERIAL ANALYSES

Material	Composition (approx.)	Degree of Hardness	Density
Agate	99.9% SiO ₂	7.0 Mohs	app. 2 600 kg/m ³
Hard porcelain	71.0% SiO ₂ , 24.0% Al ₂ O ₃	7.0 Mohs	app. 2 400 kg/m ³
Sintered corundum I	99.7% Al ₂ O ₃	9.0 Mohs	app. 3 900 kg/m ³
Zirconia	97.0% ZrO ₂	8.5 Mohs	app. 5 700 kg/m ³
Stainless steel	84.5% Fe, 13.0% Cr	53 HRC ≅ app. HV = 5.7 GPA	app. 7 700 kg/m ³
Chrome steel 2	86.0% Fe, 11.5% Cr	60 HRC ≅ app. HV = 7 GPA	app. 7 700 kg/m ³
Tungsten carbide	94.0% WC, 6.0% Co	HV = 1150 kg/mm ² ≅ 11.2 GPA	app. 14 400 kg/m ³
Vulkollan		app. 80 Shore	app. 1 300 kg/m ³

REFERENCES

MORTAR GRINDER RM 100		Article-No.
Type RM 100, 230 V, 50 Hz		20.452.0001
Type RM 100, 110 V, 60 Hz		20.452.0003
Grinding sets		Article-No.
Material	Mortar	Pestle
Agate	01.460.0019	02.461.0010
Hard procelain	02.460.0016	02.461.0007
Sintered corundum I	02.460.0017	02.461.0008
Zirconia	02.460.0025	02.461.0030
Stainless steel	02.460.0057	03.461.0009
Chrome steel 2	02.460.0018	03.461.0041
Tungsten carbide	02.460.0021	05.461.0027
Accessories		Article No.
Scraper of beech wood		05.008.0017
Replacement parts		Article No.
Scraper of vulkollan		05.862.0009

Mortar Grinders with 300 or 1.000 ml useful volume upon request



RM 100 MECHANICS

Grinding, mixing and trituration are effected as with a manual mortar and pestle by means of pressure and friction. In the RM 100 mortar grinder, the feed material is conveyed into the grinding gap between the mortar and the pestle by the rotating mortar and the scraper. This forced feed ensures that the whole sample quantity is repeatedly subjected to the grinding and trituration process and is intensively mixed. The pestle is arranged off-centre to the mortar. Through the contact with the rotating mortar or material being ground it rotates automatically along with the mortar. The grinding pressure arises due to the deadweight of the pestle and the spring pressure acting on the pestle axis.

The mortar is driven by a 0.130 kW geared motor. This is protected against overload by a motor protecting switch. The rotary speed of the mortar is 90 rpm and the type of protection for the mill is IP 53.

The grinding compartment cover has a safety switch which cuts out when the lid is opened. The RM 100 is an especially high-performance, universal mortar grinder and complies with the German and European safety directives.

WEIGHTS AND MEASURES

W x H x D	400 x 450 x 370 mm
Weight	appr. 24 kg (w/o set)

RETSCH GmbH & Co. KG
 Rheinische Strasse 36
 D - 42781 Haan - Germany
 Tel. +49 (0) 21 29 / 55 61-0
 Fax. +49 (0) 21 29 / 87 02

Retsch

RETSCH offers a comprehensive programme of equipment for sample preparation of solids. Please ask for information on our crushers, mills, sample dividers, sieving machines, feeders, mixers, cleaning and drying devices. All documents are sent free of charge and without obligation.

Technical modifications reserved

99.452.0001/E
 Made in Germany 11/95