

PLANETARY BALL MILL PM 400



GRINDING

RETSCH high-speed planetary ball mills are suitable for sample preparation, quality control and development of new materials.

MIXING

RETSCH high-speed planetary ball mills can also be used for mixing and homogenizing, for solids and suspensions.

ALLOYING

RETSCH high-speed planetary ball mills in special designs are ideal for mechanical alloying of hard and brittle materials.

ADVANTAGES

- Extreme fineness right down into the submicron range
- Fast, no-loss pulverization and mixing, either wet or dry
- Grinding two, four or eight samples simultaneously.
- Reproducible results with digital adjustments and constant speed
- Twin grinding chamber fans
- Universal application thanks to a wide range of accessories and grinding jars available in four sizes and seven different materials
- Simple, convenient and safe operation
- Stable, rugged, noise-insulated design complying with CE requirements
- High product throughput rates as a result of short grinding periods

FEATURES

application	size reduction, mixing, homogenizing, mechanical alloying
feed stock	soft, hard, brittle, fibrous
feed size	< 10 mm
final fineness	< 1 µm
sample volume	max. 4 x 250 ml or 8 x 20 ml

PLANETARY BALL MILL PM 400



High-tech with highest operating convenience: the PM 400

Retsch

The RETSCH planetary ball mill pulverizes and mixes soft, medium-hard and even extremely hard, brittle and fibrous materials. Both wet and dry grinding is possible. The PM 400 can be used to reduce minerals, ores, alloys, chemicals, glass, ceramics, plant material, soils, sewage sludge, household and industrial refuse, and many other substances -- simply, quickly and without loss. The Planetary ball mills have been used successfully in almost every field of industry and research, particularly where the requirements for purity, speed, reproducibility and fineness are extreme. Fineness levels down to 0.03 μm have been reached, for instance. Grinding jars and balls in seven different materials ensure analysis results are free from contamination. The extreme centrifugal forces mean high pulverization energies and thus short grinding periods. Four grinding stations, for two, four or eight jars, allow rapid turnaround of samples. For fewer samples it is also possible to obtain the mill with 2 grinding points.

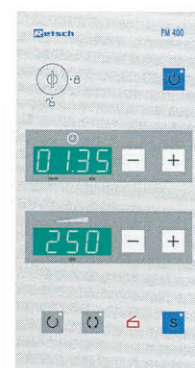

The PM 400 is distinguished by a user-friendly touch pad key panel with digital speed adjustment from 30 to 400 rpm, a real-time display, digital time specification up to 99.99 h, rotational direction reversing control (running and pause time can be freely programmed) and service code along with new, patented, quick-action safety clamps for the grinding jars. The rugged, compact stand-alone unit (incl. castor) ensures smooth running even at maximum speeds.

The high-performance, low-maintenance drive makes it possible to carry out extended grinding times or -- if you select the special DLR version -- to undertake mechanical alloying.

HIGH-PERFORMANCE, SAFE, CONVENIENT



GRINDING JARS AND BALLS

The performance and the results of sample preparation are determined primarily by the choice of grinding jar and ball charge. The selection will depend on the quantity to be handled, the final particle size required and the purity of the ground product. The adjacent tables make it possible to select a suitable mixing configuration, depending on the quantity of the sample and the grain size of the feed material.

Large balls are normally used for coarse reduction, smaller ones for finer grinding. The greater the density of the material from which the balls are made, the higher the pulverization energy applied. Since wear is often not avoidable in pulverization, the material for the jar and the balls should be selected so that any dust which is generated will not interfere with subsequent analyses.

The series "C" grinding jars were specially line was developed for use in extreme conditions such as prolonged testing, high mechanical loading and maximum speeds; these models are also suitable for mechanical alloying.

Less demanding operating conditions (e.g. short grinding periods and/or low masses) can normally be met by using the more economical "S" version (information on request).

ADVANTAGES OF THE TYPE "C" GRINDING JARS

1. Protective jacket made of stainless steel (for all ceramic, agate and WC jars)
2. Positive O-ring seals on lids
3. The gap between the jar and the edge of the lid simplifies opening
4. Anti-rotation feature, non-slip seating due to exact centering
5. Identification of the grinding jar (item number, material and volume)
6. Space for user labeling (e.g. product being processed)
7. Flanges on the jar and lid facilitate handling

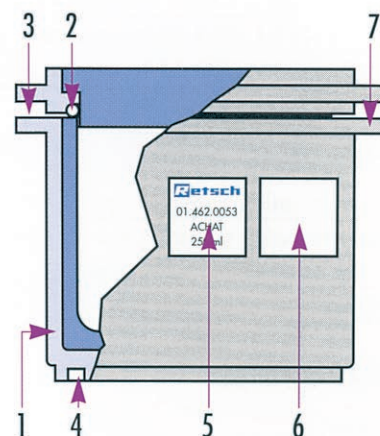

GRINDING JARS AND BALL CHARGES

jars type "C" rated volume	eff. volume (material and balls)	max. feed particle size	recommend ball charge			
			Ø 40 mm	Ø 30 mm	Ø 20 mm	Ø 10 mm
50 ml	5 - 30 ml	< 3 mm	-	-	3 pcs.	10 pcs.
125 ml	15 - 80 ml	< 4 mm	-	-	6 pcs.	25 pcs.
250 ml	25 - 150 ml	< 6 mm	-	5 pcs.	12 pcs.	50 pcs.
500 ml	75 - 300 ml	< 10 mm	4 pcs.	8 pcs.	20 pcs.	100 pcs.

MATERIAL ANALYSES

Grinding set Type "C"	Composition (approx.)	Degree of Hardness	Density
Agate	99.9% SiO ₂	7.0 Mohs	app. 2 600 kg/m ³
Sintered corundum I	99.7% Al ₂ O ₃	9.0 Mohs	app. 3 900 kg/m ³
Silicon nitride	53.0% Si, 35.2% N, 3.5% I, 2.5% Al, 0.5% Mg	HV = 1400 kg/mm ² ± 14 GPA	app. 3 200 kg/m ³
Zirconia	97.0% ZrO ₂	8.5 Mohs	app. 5 700 kg/m ³
Stainless steel	84.5% Fe, 13.0% Cr	53 HRC ± app. HV = 5.7 GPA	app. 7 700 kg/m ³
Chrome steel 2	86.0% Fe, 11.5% Cr	60 HRC ± app. HV = 7 GPA	app. 7 700 kg/m ³
Chrome steel 4	84.0% Fe, 13.5% Cr	53 HRC ± app. HV = 5.7 GPA	app. 7 700 kg/m ³
Tungsten carbide	94.0% WC, 6.0% Co	HV = 1150 kg/mm ² ± 11.2 GPA	app. 14 400 kg/m ³

REFERENCES

PLANETARY BALL MILL PM 400	Article-No.
Type PM 400, 1 x 220 - 230 V, 50 - 60 Hz, with 4 grinding points	20.532.0001
Type PM 400, 1 x 240 V, 50 - 60 Hz, with 4 grinding points	20.532.0002
Type PM 400/2, 1 x 220 - 230 V, 50 - 60 Hz, with 2 grinding points	20.532.0005
Type PM 400/2, 1 x 240 V, 50 - 60 Hz, with 2 grinding points	20.532.0006
Type PM 400 DLR, 230 V, 50 Hz, special execution for mechanical alloying (1:-1.5)	20.533.0001
Type PM 400 DLR, 230 V, 50 Hz, special execution for mechanical alloying (1:-2)	20.533.0002

The PM 400 is supplied in series with rollers

Accessories	Article-No.
Adapter for stacking grinding jars type "C", 50 ml, stainless steel, chrome steel	03.025.0002
Adapter for stacking grinding jars type "C", 50 ml, agate, sintered corundum, zirconia, silicon nitride, tungsten carbide	03.025.0003
Safe-lock fixture for hazardous materials for grinding jars 250 ml, 125 ml and 50 ml	82.654.0001

Grinding jars Type "C"	Article-No.			
Material	500 ml	250 ml	125 ml	50 ml
Agate	01.462.0130	01.462.0133	01.462.0136	01.462.0139
Sintered corundum I	01.462.0150	01.462.0151	01.462.0152	01.462.0153
Silicon nitride	01.462.0132	01.462.0135	01.462.0138	01.462.0141
Zirconia	01.462.0131	01.462.0134	01.462.0137	01.462.0140
Stainless steel	01.462.0146	01.462.0147	01.462.0148	01.462.0149
Chrome steel 2	01.462.0142	01.462.0143	01.462.0144	01.462.0145
Tungsten carbide	—	01.462.0154	01.462.0155	01.462.0156

Grinding jars type "S", refer to Centrifugal Ball Mills or upon request

Grinding balls	Article-No.			
Material	40 mm Ø	30 mm Ø	20 mm Ø	10 mm Ø
Agate	05.368.0064	05.368.0065	05.368.0028	05.368.0067
Sintered corundum I	05.368.0052	05.368.0053	05.368.0054	05.368.0021
Silicon nitride	05.368.0087	05.368.0086	05.368.0085	05.368.0088
Zirconia	05.368.0072	05.368.0073	05.368.0074	05.368.0075
Stainless steel	05.368.0060	05.368.0061	05.368.0062	05.368.0063
Chrome steel 4	05.368.0056	05.368.0057	05.368.0033	05.368.0059
Tungsten carbide	05.368.0068	05.368.0069	05.368.0070	05.368.0071

CHARACTERISTIC NOISE VALUES (DIN 45635-31-01-KL3)

Workplace-related emission value $L_{pA eq} = 66$ dB
 Grinding set: 4 x 250 ml ZrO_2 each with 50 balls 10 mm Ø
 Material: Quartz sand, 90 g/jar Speed: 400 min⁻¹

F. Kurt RETSCH GmbH & Co. KG
 Rheinische Strasse 36 · D - 42781 Haan
 POB 15 54 · D - 42759 Haan
 Tél.: +49 (0) 21 29 / 55 61-0
 Fax.: +49 (0) 21 29 / 87 02
 E-Mail: info@retsch.de
 Internet: http://www.retsch.de

RetSch®

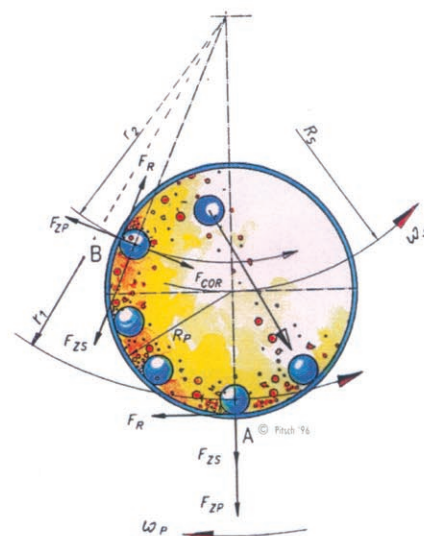

PM 400 MECHANICS

The grinding jars for the planetary ball mill are arranged in such a way that each moves around its own axis and, in the opposite direction, around the common axis of the sun wheel – all this at uniform speed and uniform rotation ratios. The result is that the superimposition of the centrifugal forces changes constantly (Coriolis motion). The grinding balls describe a semi-circular movement, separate from the inside wall and collide with the opposite surface at high impact energy. The impact and friction forces are the reasons for the impressive size reduction power of the PM 400.

The sun wheel is driven by a rugged, high-power 1500-W motor. A frequency converter is provided to adjust speed infinitely within a range from 30 to 400 rpm; speed is kept constant via an electronic controller.

In the special version for mechanical alloying, impact energy is boosted by modifying the rotation ratio between the jars and the sun wheel, raising it from 1:-1 to a ratio of 1:-1.5 or 1:-2.

WEIGHTS AND MEASURES

W x H x D	820 x 1.070 x 685 mm
Weight	app. 285 kg

RETSCH offers a comprehensive programme of equipment for sample preparation of solids. Just ask for information on our crushers, mills, sample dividers, sieving machines, feeders, mixers, cleaning and drying devices. You will receive all documents free of charge and without obligation.

Technical modifications reserved

99.532.0002/E
 Printed in Germany 09/96