

SONOREX – SONOPULS

High-power ultrasound in laboratories

Cleaning – Homogenizing – Dispersing – Degassing



SONOCOOOL®



BactoSonic®



BANDELIN

60 years of experience in ultrasound

Recommendations on ultrasonic cleaning

How does ultrasound work?

Vibrations at frequencies exceeding 18 kHz (18,000 vibrations per second) are called ultrasound. As a result of these vibrations millions of smallest vacuum bubbles are formed in liquids. They implode during the high pressure phase and create highly effective pressure waves. This process is called cavitation and causes the removal of dirt particles from the objects to be cleaned.

Lower frequencies of approx. 20 kHz which are applicable in cell disruption, produce bubbles with larger diameters and stronger pressure waves than higher frequencies of approx. 35 kHz which are used for intense but gentle cleaning.

The HF generator converts the mains frequency into the corresponding frequency of the ultrasonic bath. This frequency is transformed into mechanical vibrations by transducers underneath the tank.

Ultrasound is transmitted to the liquid in the bath.

All ultrasonic baths (except DK-units) use **SweepTec®** – a special frequency modulation around an optimally fixed operating point. A very homogeneous and even ultrasonic field is achieved.

Advantages of ultrasonic cleaning

Ultrasonic cavitation removes dirt rapidly from items, thoroughly and deep from pores, even from difficult to reach places such as cavities or holes.

Ultrasound cleans only in a few minutes and exceeds in its efficiency other cleaning methods.

Ultrasonic cleaning is also gentle because even slight damage like scratches are eliminated.

Advantages in process engineering and sonochemistry

Cavitation not only can be used for various purposes, but a very fine emulsion of oil and water can be produced by ultrasonic application. Compared to other manufacturing processes this emulsion is more stable.

For sonochemical processes in an ultrasonic bath, the reaction vessel should have a thin bottom. Thus, the ultrasonic energy is radiated directly and effectively into the reaction vessel.

How to select the proper unit

SONOREX ultrasonic baths work with the intense cleaning frequency of 35 kHz.

Size and number of objects to be cleaned determine size of the ultrasonic bath.

When selecting the unit, dimensions of the accessories, e. g. baskets have to be considered. To avoid overloading, it is recommended to choose a slightly larger unit.

This also allows additional applications at a later stage.

Should an ultrasonic unit have a heating?

Warm cleaning solutions reduce the cleaning time; dirt is removed faster. Units with heaters are the preferred choice for cleaning processes in laboratories.

Disinfectant solutions must not be warmed-up because protein coagulation starts at a temperature of 40 °C (104° F) and this poses an obstacle for some cleaning and all disinfection processes. Therefore, units without heaters are recommended for these applications.

What kind of accessories should be used?

Objects to be cleaned and reaction vessels must not be placed on the tank bottom.

Insert baskets avoid scratching either the parts to be cleaned or the tank bottom. Beakers are placed into positioning lids and are used for cleaning of small objects or when working with aggressive solutions.

Which cleaning agents are appropriate?

TICKOPUR and STAMMOPUR cleaning and disinfectant agents have been especially developed for application in SONOREX ultrasonic baths. Water without any cleaning agent does not clean.

Household detergents as well as DI-water should never be used. It is necessary to use plastic insert tubs, when working with acids or removing acid residues.





Flammable liquids must not be used directly in the ultrasonic tank.



BANDELIN *electronic*

specialized in manufacturing of ultrasonic units, maintain a quality management system complying with the requirements of EN ISO 9001 / 12.2000 and EN ISO 13485:2003 + AC:2007

Overview on **SONOREX** ultrasonic baths

Features				
	DIGITEC	SUPER	DIGITAL 10 P	LONGLIFE
Tank volume (litres)	0.9–90.0	0.9–58.0	3.0–28.0	1.9–90.0
Control elements	push-buttons	turning knobs	push-buttons	turning knobs
Time setting (min)	1–30, continuous operation [∞]	1–15, continuous operation [∞]	1–99, continuous operation [∞]	1–15, continuous operation [∞]
Safety shut-down	after 12 hours	no	no	no
Heating	optional, version "H"	optional, H-Version	yes	yes
Heating, thermostatically adjustable	20–80 °C	30–80 °C RK 31 H: 65 °C fixed	20–80 °C	30–80 °C
Excess temperature signal	yes	no	no	no
Protection against delay in boiling	yes, optionally switch-on	no	no	no
Setting accuracy of bath temperature	± 3.5 K	± 5 K	± 1.5 K	± 5 K
Thickness of stainless steel tank material version "C"	0.8 mm. AISI 314 2 mm. AISI 316 Ti	0.8 mm. AISI 304 2 mm. AISI 316 Ti	0.8 mm. AISI 304 -	- 2 mm. AISI 316 Ti
Marking of filling level for safe dosage	yes	yes	yes	yes
Hard chromium-plated	DT 102 H	RK 102 H	no	no
Lifetime	normal, extended: version "C" hard chromium-plated	normal, extended: hard chromium-plated	normal	extended
Warranty period (years)	2, DT 102 H = 3	2, RK 102 H = 3	2	3
One-piece drain, welded	yes, from DT 100 SH	yes, from RK 100 SH	yes, from DK 156 BP	yes, from RK 102 CH
Liquid protection	protected against spray	drip-proof	drip-proof	drip-proof
Degree of protection	IP 33	IP 32	IP 32	IP 32
Ultrasonic frequency (kHz)	35	35	35	35
Sweep	yes	yes	no	yes
Power adjustment	no	no	yes	no
PCT-transducers (PCT = lead circonate titanate)	yes	yes	yes	yes
Fast degassing	yes	no	yes	no
Mains supply 230 V~, 50/60 Hz	yes	yes	yes	yes
alternatively: mains supply 115 V~, 50/60 Hz	yes	yes	no	yes
Data memory	1 program (type H-RC)	no	10 programs	no
Interface	RS 232, type H-RC	no	no	no
PC software	yes	no	no	no
CE marked as medical device	yes, except for DT 1050 / CH	yes, except for RK 1050	no	yes, except for RK 1050 CH

For units with larger volumes (SONOREX TECHNIK) see last page.

Digital high-power ultrasonic baths with fast degassing

- ➔ Cleaning of technical glassware like burettes, pipettes, petri dishes and laboratory flasks
- ➔ disinfection and cleaning at the same time
- ➔ Degassing of beer samples for analysis of alcohol contents, original worth, colour, pH value
- ➔ Degassing of food samples from cans for analysis of stannous contents
- ➔ Extraction of quaternary ammonium compounds (QAC) of wood
- ➔ Extraction of herbs samples for determination of aflatoxines (causing mold decay on food)
- ➔ Extraction of soil samples for determination of hydrocarbons
- ➔ Test method for freeze-thaw resistance of concrete: CDF test – through sonication, loosely adhering scaled particles are removed from surface



Internal tank dimensions (l x w x d) mm	Capacity litres	Type	Code No.	External dimensions (l x w x h) mm	Drain ball valve	Ultrasonic peak output * W	HF output	Heating power	Current consumption A	Weight net kg
							W _{eff}	W		
190 x 85 x 60	0.9	DT 31	3200	205 x 100 x 170	-	240	30	-	0.2	1.8
		DT 31 H	3220				30	70		
150 x 140 x 100	1.8	DT 52	3205	175 x 165 x 230	-	240	60	-	0.3	2.6
		DT 52 H	3225				60	140		
240 x 140 x 100	3.0	DT 100	3210	260 x 160 x 250	-	320	80	-	0.4	3.4
		DT 100 H	3230		-	320	80	140	1.0	3.6
		DT 102 H	3235		G ¼	480	120	140	1.2	4.3
240 x 140 x 150	4.0	DT 103 H	3201	260 x 160 x 310	G ¼	560	140	200	1.5	4.6
Ø 240 x 130	5.6	DT 106	3270	Ø 265 x 270	G ¼	480	120	-	0.6	5.5
500 x 140 x 100	6.0	DT 156	3275	530 x 165 x 245	G ¼	640	160	-	0.7	6.1
500 x 140 x 150	9.0	DT 156 BH	3221	530 x 165 x 300	G ¼	860	215	600	3.6	7.3
300 x 150 x 150	5.5	DT 255	3215	325 x 175 x 295	G ¼	640	160	-	0.7	5.2
		DT 255 H	3240		G ¼	640	160	280	2.0	5.3
300 x 240 x 150	9.7	DT 510	3245	325 x 265 x 305	G ½	640	160	-	0.7	7.0
		DT 510 H	3206		G ½	640	160	400	2.5	7.6
300 x 240 x 200	13.0	DT 512 H	3226	325 x 265 x 350	G ½	860	215	400	2.7	8.0
325 x 300 x 150	13.5	DT 514	3250	355 x 325 x 305	G ½	860	215	-	1.0	8.2
		DT 514 H	3211		G ½	860	215	600	3.6	8.8
325 x 300 x 200	18.7	DT 514 BH	3216	355 x 325 x 385	G ½	860	215	600	3.6	9.8
500 x 300 x 200	28.0	DT 1028	3255	535 x 325 x 400	G ½	1200	300	-	1.4	14.3
		DT 1028 H	3231		G ½	1200	300	1300	7.0	14.7
500 x 300 x 300	45.0	DT 1028 CH	3266	540 x 340 x 500	G ½	1200	300	1450	7.7	23.7
600 x 500 x 200	58.0	DT 1050	3265	655 x 535 x 425	G ½	2400	600	-	2.7	31.0
600 x 500 x 300	90.0	DT 1050 CH	3271	640 x 540 x 530	G ½	2400	600	1950	11.1	37.0

*To achieve an improved efficiency, the ultrasound is modulated whereby in combination with SweepTec and depending on the tank model four times or eight times higher values of the HF output are obtained as ultrasonic peak output.

High-power ultrasonic baths with infrared interface for process documentation

- ⇒ Degassing of liquids
- ⇒ Acceleration of suspending processes
- ⇒ Emulsifying
- ⇒ Sample preparation for analysis



starting screen



DT 102 H-RC with IR 1

WINSONIC® DT remote control

- The PC program is designed for operating systems MICROSOFT® WINDOWS®2000 and MICROSOFT® WINDOWS® XP in connection with the infrared adapter IR 1 allowing a comfortable operation and monitoring of DIGITEC DT ... RC ultrasonic baths.
- The status window gives an updated overview on the working conditions.
- Start time and stop time as well as the respective bath temperature are automatically collected in log files. This way, a documentation of the cleaning process is possible for quality assurance.

WINSONIC® DT remote control consisting of:

software and infrared adapter IR 1 Code No. 3090

Interface for automation of laboratories

- RS 232 data interface to the laboratory PC allows processing of individual control tasks and integration into an automated laboratory line.
- Data log is disclosed and described in a detailed information for use.
- Infrared adapter IR 1 is necessary for connection.

Internal tank dimensions (l x w x d) mm	Capacity litres	Type	Code No.	External dimensions (l x w x h) mm	Drain ball valve	Ultrasonic peak output * W	HF output W _{eff}	Heating power W	Current consumption A	Weight net kg
240 x 140 x 100	3.0	DT 102 H-RC	3071	260 x 160 x 250	G ¼	480	120	140	1.2	4.3
300 x 150 x 150	5.5	DT 255 H-RC	3081	325 x 175 x 295	G ¼	640	160	280	2.0	5.3
300 x 240 x 150	9.7	DT 510 H-RC	3091	325 x 265 x 305	G ½	640	160	400	2.5	7.6
325 x 300 x 200	18.7	DT 514 BH-RC	3095	355 x 325 x 385	G ½	860	215	600	3.6	9.8

*To achieve an improved efficiency, the ultrasound is modulated whereby in combination with SweepTec a four times higher value of the HF output is obtained as ultrasonic peak output.

Robust ultrasonic baths

- easy to operate

- ⇒ Cleaning of
 - technical glassware like burettes, pipettes, petri dishes and laboratory flasks
 - analysis sieves up to 400 mm diameter
 - medical instruments
 - metal parts of all kinds
 - electronic components
- ⇒ Degassing of liquids to determine concentration
- ⇒ Acceleration of suspending processes
- ⇒ Disinfecting and cleaning at the same time
- ⇒ Production of emulsions
- ⇒ Preparation of samples for analysis, e. g. analysis of hair



Internal tank dimensions (l x w x d) mm	Capacity litres	Type	Code No.	External dimensions (l x w x h) mm	Drain ball valve	Ultrasonic peak output * W	HF output W _{eff}	Heating power W	Current consumption A	Weight net kg
190 × 85 × 60	0.9	RK 31	329	205 × 100 × 170	-	240	30	-	0.2	1.8
		RK 31 H	044		-	240	30	70	0.5	1.9
150 × 140 × 100	1.8	RK 52	311	175 × 165 × 225	-	240	60	-	0.3	2.6
		RK 52 H	164		-	240	60	140	0.9	2.9
240 × 140 × 100	3.0	RK 100	301	260 × 160 × 250	-	320	80	-	0.4	3.4
		RK 100 H	312		-	320	80	140	1.0	3.6
		RK 100 SH	192		G ¼	320	80	140	1.0	4.0
		RK 102 H	303		G ¼	480	120	140	1.2	4.3
240 × 140 × 150	4.0	RK 103 H	326	260 × 160 × 310	G ¼	560	140	200	1.5	4.3
Ø 240 × 130	5.6	RK 106	306	Ø 265 × 270	G ¼	480	120	-	0.6	5.5
500 × 140 × 100	6.0	RK 156	305	530 × 165 × 245	G ¼	640	160	-	0.7	6.1
500 × 140 × 150	9.0	RK 156 BH	646	530 × 165 × 300	G ¼	860	215	600	3.6	7.3
300 × 150 × 150	5.5	RK 255	3066	325 × 175 × 305	G ¼	640	160	-	0.7	5.2
		RK 255 H	316		G ¼	640	160	280	2.0	5.3
300 × 240 × 150	9.7	RK 510	327	325 × 265 × 305	G ½	640	160	-	0.7	7.0
		RK 510 H	321		G ½	640	160	400	2.5	7.6
300 × 240 × 200	13.0	RK 512 H	795	325 × 265 × 350	G ½	860	215	400	2.7	8.0
325 × 300 × 150	13.5	RK 514	277	355 × 325 × 305	G ½	860	215	-	1.0	8.2
		RK 514 H	207		G ½	860	215	600	3.6	8.8
325 × 300 × 200	18.7	RK 514 BH	263	355 × 325 × 385	G ½	860	215	600	3.6	9.8
500 × 300 × 200	28.0	RK 1028	322	535 × 325 × 400	G ½	1200	300	-	1.4	14.3
		RK 1028 H	324		G ½	1200	300	1300	7.0	14.7
500 × 300 × 300	45.0	RK 1028 C	661	540 × 340 × 500	G ½	2000	500	-	2.2	24.6
Ø 500 × 195	39.5	RK 1040	319	Ø 540 × 500	G ½	1200	300	-	1.4	20.5
600 × 500 × 200	58.0	RK 1050	323	655 × 535 × 425	G ½	2400	600	-	2.7	31.0

*To achieve an improved efficiency, the ultrasound is modulated whereby in combination with SweepTec and depending on the tank model four times or eight times higher values of the HF output are obtained as ultrasonic peak output.

High-power ultrasonic baths with power adjustment, fast degassing and 10 program data memory

- ⇒ Degassing of solvents for HPLC
- ⇒ Accelerating of chemical reactions
- ⇒ Mixing of plasma and sera
- ⇒ Emulsifying
- ⇒ Homogenizing of samples for residue analysis in vegetarian food
- ⇒ Preparation for pollutant analysis of drinking or drain water
- ⇒ Preparation of liposomes in cosmetics and pharmacy
- ⇒ Preparation of samples for analysis of THC-content in cannabis



Exact setting of all parameters guarantees reproducible results. When switching off the unit, the data are stored automatically.

Selection of Time • Temperature • Power • DEGAS • Storage of up to 10 variations

Time Setting between 1 to 99 min and continuous operation. Interruption is possible at any time. Display of remaining time.	Temperature Heating adjustable between 20 to 80 °C (68 to 176° F). Display REAL: Bath temperature Display SELECT: Required temperature Integrated thermometer, accuracy ± 1.5° C.	Power Setting from 10 to 100 %. Microprocessor controlled. Power constancy guarantees exact reproducibility.	DEGAS Rapid degassing of liquids. Higher degassing rates in HPLC-technique.
---	--	--	---

Internal tank dimensions (l x w x d) mm	Capacity litres	Type	Code No.	External dimensions (l x w x h) mm	Drain ball valve	Ultrasonic peak output W	HF output W _{eff}	Heating power W	Current consumption A	Weight net kg
240 x 140 x 100	3.0	DK 102 P	780	260 x 160 x 250	-	480	120	140	1.2	4.5
500 x 140 x 150	9.0	DK 156 BP	781	530 x 165 x 300	G ¼	720	180	600	3.4	7.6
300 x 150 x 150	5.5	DK 255 P	782	325 x 175 x 295	G ¼	640	160	280	2.0	6.0
300 x 240 x 200	13.0	DK 512 P	783	325 x 265 x 350	G ½	820	205	400	2.7	8.8
325 x 300 x 200	18.7	DK 514 BP	784	355 x 325 x 385	G ½	860	215	600	3.6	10.2
500 x 300 x 200	28.0	DK 1028 P	786	535 x 325 x 400	G ½	1200	300	1300	7.0	15.2

SONOREX LONGLIFE

Heavy-duty ultrasonic cleaning baths with 2 mm stainless steel, AISI 316Ti

- ⇒ Removal of stubborn dirt in service and maintenance
- ⇒ Direct application of high purity water possible
- ⇒ RK 1028 CH and RK 1050 CH for cleaning and disinfection of respiratory masks



Internal tank dimensions (l x w x d) mm	Capacity litres	Type	Code No.	External dimensions (l x w x h) mm	Drain ball valve	Ultrasonic peak output W	HF output W _{eff}	Heating power W	Current consumption A	Weight net kg
220 x 135 x 100	3.0	RK 102 CH	3031	260 x 175 x 275	G ¼	480*	120	200	1.4	5.6
220 x 135 x 150	4.5	RK 103 CH	3032	260 x 175 x 325	G ¼	560*	140	200	1.6	6.4
280 x 150 x 150	6.3	RK 255 CH	3033	320 x 190 x 325	G ¼	720*	180	280	2.0	7.9
280 x 234 x 200	13.1	RK 512 CH	3034	320 x 275 x 380	G ½	1200*	300	560	3.5	13.6
280 x 234 x 300	19.7	RK 515 CH	3035	320 x 275 x 485	G ½	1200*	300	700	4.4	16.0
500 x 300 x 300	45.0	RK 1028 CH	143	540 x 340 x 500	G ½	1200*	300	1450	7.7	23.7
600 x 500 x 300	90.0	RK 1050 CH	184	640 x 540 x 530	G ½	2400*	600	1950	11.1	37.0

*To achieve an improved efficiency, the ultrasound is modulated whereby in combination with SweepTec a four times higher value of the HF output is obtained as ultrasonic peak output.

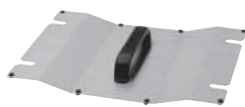

D 514

Lid D
stainless steel, to protect the liquid from outside dirt. Condensation water runs back into the tank.



KD 0



PD 04

Inset sieve baskets, mesh net, suitable for inset beakers.

KD 0
stainless steel, diameter 75 mm
PD 04
plastic, diameter 60 mm



K 14

Insert baskets K
stainless steel



SD 06



DD 06

Inset beakers
for indirect cleaning of small parts. Suitable for **DE/ES**

SD 06, glass 600 ml
PD 06, plastic 600 ml
EB 05, stainless steel 600 ml diameter 85 mm, 100 mm deep, with retaining ring and lid DD 06.
SD 09, glass with ring 1000 ml



K 14 P

Insert baskets PK...C/K...P
plastic, with perforations, for gentle cleaning of sensitive surfaces.



EB 05



PD 06

Suitable for DE 08

SD 04, glass, 400 ml
SD 05, glass, 600 ml
KB 04, plastic, 400 ml mit Ring



GH 1

Utensil holders GH, stainless steel, mesh size 12.5 × 12.5 mm for larger objects. Utensil holder **GH 1**, suitable for flasks up to a diameter of 105 mm.



DE 100

Positioning lids DE, stainless steel, for inset beakers SD 06, PD 06, EB 05 and SD 09: DE 52 for 1 beaker DE 100/6/255 for 2 beakers DE 156/510/514 for 4 beakers



GH 10

Insert tubs KW, plastic, non-perforated and with lid. For working with chemicals that corrode the stainless steel oscillating tank. Insert tubs KW are made of PP, except for **KW 3/5** made of PE. Stable up to a temperature of 80 °C (176° F) in water and up to 60 °C (140° F) in acids.



ES 4

Beaker holder ES 4
stainless steel, for 4 inset beakers SD 06, PD 06, EB 05, SD 09 - in ultrasonic baths of a larger size for optimum ultrasonic power.



KW 3

Appropriate accessories facilitate ultrasonic application and simultaneously protect oscillating tank and parts to be cleaned. Objects to be cleaned or vessels must not be placed onto the tank bottom!

Type	RK 31 / H DT 31 / H	RK 52 / H DT 52 / H	RK 100 / H RK 102 H, DK 102 P DT 100 / H DT 102 H / H-RC	RK 102 CH	RK 103 H DT 103 H
Accessories					
Lids, s/s	D 08	D 52	D 100	D 100	D 100
Insert baskets, s/s l × w × h (mm)	K 08 170 × 65 × 50	K 1 C 120 × 110 × 40	K 3 C 200 × 110 × 40	K 3 C 200 × 110 × 40	K 3 CL 200 × 110 × 40
Insert baskets, plastic l × w × h (mm)	-	PK 1 C 90 × 90 × 66	PK 2 C 187 × 90 × 56	PK 2 C 187 × 90 × 56	PK 3 C 187 × 90 × 56
Utensil holders l × w × d (mm)	-	GH 1 129 × 117	GH 1 129 × 117	GH 1 129 × 117	GH 1 129 × 117
Insert tubs l × w × d (mm)	-	-	KW 3 195 × 115 × 88	-	KW 3 195 × 115 × 88
Positioning lids	DE 08	DE 52	DE 100	DE 100	DE 100
Type	RK 510 / H DT 510 / H / H-RC	RK 512 H / CH DT 512 H DK 512 P	RK 514 / H DT 514 / H	RK 514 BH DT 514 BH / BH-RC DK 514 BP	RK 515 CH
Accessories					
Lids, s/s	D 510	D 510	D 514	D 514	D 510
Insert baskets, s/s l × w × h (mm)	K 10 250 × 195 × 50	K 10 B 250 × 195 × 50	K 14 275 × 245 × 50	K 14 B 275 × 245 × 50	K 15 C 250 × 190 × 50
Insert baskets, plastic l × w × h (mm)	-	-	K 14 P 230 × 250 × 45	-	-
Utensil holders l × w × d (mm)	GH 10 260 × 200	GH 10 B 260 × 200	-	GH 14 B 280 × 250	-
Insert tubs l × w × d (mm)	KW 10-0 242 × 182 × 136	-	KW 14 280 × 215 × 145	KW 14 B 275 × 210 × 195	-
Positioning lids	DE 510	DE 510	DE 514	DE 514	DE 510
Beaker holder					

Special accessories



K 10 with 2 EK 100

Spring clamps for laboratory flasks

Neither floating nor canting of flasks. Fast and easy fixing to the bottom of insert baskets or utensil holders, with mesh sizes up to 12.5 x 12.5 mm.

EK 10, for 10-ml-Laboratory flask
EK 25, for 25-ml-Laboratory flask
EK 50, for 50-ml-Laboratory flask
EK 100, for 100-ml-Laboratory flask
EK 250, for 250-ml-Laboratory flask

Suitable for baskets K 3 C/CL, K 5 C, K 6, K 10/B, K 14/B, K 28/C, utensil holders GH 5, GH 10/B, GH 14/B, GH 28, and flask holders GL 100 F, 510 F and shaking device SA 1028

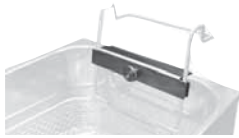

GV 10

Handle adjustment for insert baskets and utensil holders registered pattern DE 200 017 14

Stepless adjustment of immersion depth, no floating, tipping over or flooding of laboratory flasks. Quick and easy to attach.

GV 3 - 2 pieces
 suitable for baskets K 1 C, K 3 C/CL, K 5 C, K 6 L, K 6 BL and utensil holder GH 5
GV 10 - 2 pieces
 suitable for baskets K 10/B, K 14/B, K 28/C and utensil holders GH 10/B, GH 14/B, GH 28



RG 2

Test tube holder

RG 2, stainless steel

For sonication of 6 test tubes up to a diameter of 25 mm and 8 test tubes up to a diameter of 16 mm. Also applicable as a test tube rack. Contents of the test tubes remain visible.

Suitable for ultrasonic units SONOREX DIGITEC DT 52 / H, DT 100 / H / SH, DT 102 H / H-RC, SONOREX SUPER RK 52/H, RK 100 / H / SH, RK 102 H, SONOREX DIGITAL DK 102 P

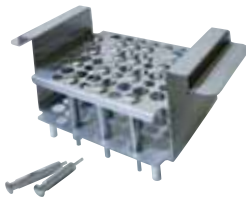

TH 14 B-S 22

Tabletting punch holder

For tabletting punches with different diameters:

TH 14 B-S 22 for RK/DT 514 BH
 holes with dia. 22 mm for 60 punches EU B

TH 14 B-S 28 for RK/DT 514 BH
 holes with dia. 28 mm for 52 punches EU D

TH 28-S 22 for RK/DT 1028 H
 holes with dia. 22 mm for 44 punches EU B

TH 28-S 28 for RK/DT 1028 H
 holes with dia. 28 mm for 31 punches EU D

TH 28 C-S 22 for RK/DT 1028 CH
 holes with dia. 22 mm for 44 punches EU B

TH 28 C-S 28 for RK/DT 1028 CH
 holes with dia. 28 mm for 31 punches EU D

RK 103 CH	RK 106 DT 106	RK 156 DT 156	RK 156 BH DK 156 BP DT 156 BH	RK 255 / H DT 255 / H / H-RC DK 255 P	RK 255 CH
D 100	D 6	D 156	D 156	D 255	D 255
K 3 CL 200 x 110 x 40	K 6 Ø 215 x 50	K 6 L 460 x 100 x 50	K 6 BL 460 x 100 x 50	K 5 C 260 x 110 x 40	K 5 C 260 x 110 x 40
PK 3 C 187 x 90 x 56	-	-	-	K 5 P 254 x 96 x 130	-
GH 1 129 x 117	-	-	-	GH 5 270 x 120	-
-	-	-	-	KW 5 254 x 96 x 130	-
DE 100	DE 6	DE 156	DE 156	DE 255	DE 255
RK 1028 / H DT 1028 / H DK 1028 P	RK 1028 C RK 1028 CH DT 1028 CH	RK 1040	RK 1050 DT 1050	RK 1050 CH DT 1050 CH	
D 1028	D 1028 C	D 40	D 1050 C	D 1050 C	
K 28 455 x 245 x 50	K 28 C 455 x 245 x 50	K 40 Ø 480 x 50	K 50 545 x 450 x 50	K 50 C 545 x 450 x 50	
K 28 P 420 x 200 x 45	-	-	-	-	
GH 28 455 x 250	GH 28 C 455 x 250	-	-	GH 50 C 550 x 455	
KW 28-0 437 x 230 x 155	KW 28-0 437 x 230 x 155	-	KW 50-0 517 x 445 x 184	KW 50 B-0 520 x 445 x 284	
ES 4	ES 4	-	ES 4	ES 4	



RK 1028 C with SH 28 C



DT 106 with SH 7

Careful cleaning of analysis sieves

Analysis sieves are test equipment and require careful cleaning. Clean sieves are necessary for safe results.

Sieve holder SH 7

Code No. 314

stainless steel, for single cleaning of analysis sieves up to dia. 200 mm, max. height 50 mm, suitable for ultrasonic baths RK 106, DT 106

Sieve holder SH 28 C

Code No. 307

stainless steel, allows simultaneous cleaning of up to 5 analysis sieves dia. 200 mm, suitable for ultrasonic bath SONOREX SUPER RK 1028 C

Ultrasonic bath for single-cleaning of analysis sieves up to dia. 400 mm:
SONOREX SUPER RK 1040

Recommended cleaning concentrate: TICKOPUR R 33

Detailed documentation on request.

Pipette cleaning

Short cleaning time. No time-consuming washing. Rinsing process in the same vessel using the siphon principle - no shifting around. Accelerated circulation of pipettes. No glass breakage when used according to the operating instructions. Also suitable for burettes, other glassware and plastic pipettes. Max. length of objects to be cleaned: 765 mm.

SONOREX PR 140 C

Operating capacity 13.9 l, operating depth 765 mm, height of the device 1,130 mm, **please note that 800 mm free space above the cylindrical vessel is necessary for loading**, required floor space 335 x 255 mm, ultrasonic peak output 860 W, HF output 215 W_{eff} 35 kHz, radiating surface diameter 150 mm, timer 1 to 15 min or continuous, mains connection 230 V~, 50/60 Hz, on request 115 V~.

Quantity of pipettes to be cleaned - suitable for K 140 B:

- diameter 9,0 mm – ca. 90 pieces
- diameter 10,7 mm – ca. 55 pieces
- diameter 14,0 mm – ca. 35 pieces
- diameter 20,0 mm – ca. 15 pieces
- diameter 29,0 mm – ca. 10 pieces

SONOREX PR 140 C

Code No. 2083

Ready to operate with basket K 140 B, lid D 140, cleaning concentrate: TICKOPUR R 33 – 5 litres

Three-way valve to change from tap water to DI-water (for final rinsing)

AR 140 C, metal

Code No. 017

AR 140 CP-1, plastic

Code No. 3039

Pipette container plastic, for soaking or for final rinsing

PG 140 B, plastic

Code No. 704

Pipette basket

K 140 B, plastic

Code No. 703

Lid

D 140, made of stainless steel

Code No. 676



PR 140 C with K 140 B



dirty

cleaned by ultrasound

Cleaning and disinfecting of breathing masks in a single operation

thorough

- reliable removal of dirt from internals or even from angles and corners

gentle

- dirt residues will be removed by cavitation, also at difficult to access areas - electronic brushing
- no scratching by manual treatment

economical

- simultaneous cleaning and disinfecting of up to 15 breathing masks in one process

Ultrasonic bath SONOREX SUPER RK 514 BH

with insert basket K 14 AZ for 2 breathing masks or 1 full mask

Ultrasonic bath SONOREX LONGLIFE RK 1028 CH

with insert basket K 28 CA for 6 breathing masks

with insert basket K 28 CV for 3 full masks

Ultrasonic bath SONOREX LONGLIFE RK 1050 CH

with insert basket K 50 CA for 9 breathing masks

with insert basket K 50 CV for 6 full masks

Ultrasonic bath SONOREX TECHNIK RM 180 UH

with insert basket MK 180 A for 15 breathing masks

Detailed documentation on request.

EXAM-expertise concerning compatibility for use on surfaces:

Cleaning and disinfecting concentrate **STAMMOPUR 24**

Universal cleaning concentrate **TICKOPUR R 33** - see page 15



SONOREX LONGLIFE RK 1028 CH
with basket K 28 CA for 6 breathing masks

Why do you need special agents for ultrasonic cleaning?

Water and ultrasound without any additives do not clean!

Besides ultrasonic power, temperature and relevant processing time, specially balanced cleaning agents are also necessary to achieve optimum cleaning results. With TICKOPUR cleaning concentrates, BANDELIN offers a wide range of adequate cleaning agents.

All of the TICKOPUR cleaning agents were specially developed for ultrasonic applications. With their cavitation-aiding properties, the cleaning concentrates support the cleaning process and are gentle to the material at the same time. Depending on the cleaning tasks, either alkaline, neutral or acidic cleaning agents are recommended. They are biologically degradable and easy to dispose of. Rinsing after cleaning is necessary to remove remaining residues of cleaning agents and diluted soil particles from the parts to be cleaned.

It is not allowed to use combustible liquids directly in the ultrasonic bath.

Household cleaners, acids and most of the customary acid cleaners are improper cleaning agents because they could destroy the tank by pitting corrosion resulting finally in breakdown of the ultrasonic bath.



Optimum cleaning results with ultrasound require appropriate cleaning agents.

Contamination	Objects to be cleaned	Cleaning agents	Litres
General contamination, oily and greasy residues, soot, ink, drilling, grinding, polishing and lapping residues etc.	Glass, ceramics, plastics, rubber, steel, stainless steel, non-ferrous-, precious- and light metals, sieves, pipettes, respirators, PC-boards, glasses. Caution with tin and zinc.	TICKOPUR R 33 - EXAM-expertise universal cleaner anticorrosive, for laboratory, service and industry, gentle cleaning, mildly alkaline, pH 9.9 (1 %), dosage 1 to 5 %, 1 to 10 min	2 5 25 200
Light drilling, grinding, polishing and lapping residues, dust, soot, oily and greasy residues etc.	Glass, ceramics, plastics, rubber, steel, stainless steel, non-ferrous-, precious- and light metals.	TICKOPUR R 30 neutral cleaner - gentle cleaning, anticorrosive, neutral, pH 7 dosage 1 to 5 %, 1 to 10 min	2 5 25 200
Heavy mineral residues like chalk, silicate, phosphate, rust, cement, temper colours, metal oxides, grease and oil films etc.	Glass, ceramics, plastics, rubber, steel, stainless steel, precious metals. Not for light and non-ferrous metals, tin and zinc!	TICKOPUR R 27 special cleaner - based on phosphoric acid, anti-corrosive, acid, pH 1.9 (1 %), dosage 5 %, 1 to 10 min	2 5 25 200
Resinous residues, soot, grease, oils, waxes, pigments, coloured fog, silicon oils, flux media, oxides at copper, brass, bronze and precious metals.	Glass, ceramics, plastics, rubber, steel, stainless steel, non-ferrous- and precious metals, analysis sieves. Caution with light metals.	TICKOPUR RW 77 special cleaner with ammonia, without phosphate, gentle to material, mildly alkaline, pH 9.9 (1 %), dosage 5 %, 1 to 10 min	2 5 25 200
Coke residues, resinous residues, soot, pigments, grease, oils, waxes, silicon oils, coloured fog, drilling, grinding, polishing and lapping residues etc.	Glass, ceramics, plastics, rubber, steel, stainless steel. Not for light metals, tin and zinc!	TICKOPUR R 60 intensive cleaner saponifying, without phosphate, strongly alkaline, pH 12.8 (1 %), dosage 2 to 20 %, 1 to 10 min	2 5 25 200
General contamination, oil, grease, distillation residues, organic and inorganic residues.	Glass, optical glass, ceramics, plastics, rubber, steel, precious and light metals.	TICKOPUR R 36 special cleaner - tenside-free non foaming, gentle to material, mildly alkaline, pH 9.9 (1 %), dosage 0.25 to 5 %, 1 to 10 min	2 5 25 200
Distillation residues, organic and inorganic residues, oily and greasy residues etc.	Glass, optical glass, ceramics, plastics, rubber, steel, precious and light metals.	TICKOPUR R 32 special cleaner - without complexing agents, anticorrosive, gentle to material. To prepare with DI water. Mildly alkaline, pH 9.9 (1 %), dosage 0.25 to 5 %, 1 to 10 min	2 5 25 200
General contamination, biofilms, soot, pigments, oil- and fat-containing residues etc.	Glass, ceramics, plastics, rubber, steel, stainless steel, non-ferrous-, precious- and light metals, instruments, pipettes, respirators, protective goggles etc.	STAMMOPUR 24* - VAH certified, EXAM-expertise, simultaneous intensive cleaning and disinfection. Residue-free rinsing, neutral scent. Very gentle to material, anticorrosive. Free from aldehydes, chlorine and phenols. Extended endurance of the used solution: 3 days. Bactericidal (incl. Tb.-B.), fungicidal, virucidal (Vaccinia, BVDV, H5N1, HbV, HIV). Mildly alkaline, pH 9.4 (1 %), dosage 1 to 2 %,	2 5 25

***Use disinfectants safely. Always read the label and product information before use!**

EC-Safety Data Sheets are available as PDF-data via internet at: www.bandelin.com

All TICKOPUR agents are also suitable for immersing and wiping.

SONOREX DIGITEC DT ... F

Flat ultrasonic baths with fast degassing function for sample preparation

- ➔ Uniform sonication of samples irrespective of size and arrangement of the flasks
- ➔ same power densities in all 3 bath sizes are followed by same results in each one
- ➔ Homogenizing
- ➔ Fast degassing of samples at the push of the button
- ➔ Sample preparation in laboratory flasks



SONOREX DIGITEC DT 1028 F
with 2 flask holders GL 510 F

Basic set:

- Ultrasonic bath SONOREX DIGITEC DT 100 F, flask holder GL100 F, 250 ml TICKOPUR TR 3
- Ultrasonic bath SONOREX DIGITEC DT 510 F, flask holder GL 510 F, 250 ml TICKOPUR TR 3
- Ultrasonic bath SONOREX DIGITEC DT 1028 F, 2 flask holders GL 510 F, 250 ml TICKOPUR TR 3

TICKOPUR TR 3, concentrate for producing the contact liquid.
Spring clamps EK are necessary to fix the laboratory flasks fast and easy to the flask holder GL. Floating or canting of flasks is prevented.



Flask size Type	10 ml EK 10	25 ml EK 25	50 ml EK 50	100 ml EK 100	250 ml EK 250
Code No.	051	053	055	057	3259
for GL 100 F are suitable	8 ×	5 ×	4 ×	2 ×	2 ×
for GL 100 F are suitable	18 ×	18 ×	9 ×	6 ×	5 ×



DT 100 F



Flask holder GL 100 F
stainless steel, for DT 100 F
Code No. 3261

Lid for covering the ultrasonic tank without flask holder



Lid D 3 P
plastic, for DT 100 F
Code No. 3214



DT 510 F



Flask holder GL 510 F
stainless steel, for DT 510 and
DT 1028 F (2 pcs)
Code No. 3262



Lid D 10 P
plastic, for DT 510 F
Code No. 3246



Lid D 28 P
plastic, for DT 1028 F
Code No. 3258

Internal tank dimensions (l x w x d) mm	Capacity litres	Type	Code No.	External dimensions (l x w x h) mm	Drain ball valve	Ultrasonic peak output * W	HF output W _{eff}	Current consumption A	Weight net kg
240 × 140 × 65	1.85	DT 100 F	3241	260 × 160 × 195	-	240	60	0.4	3.0
300 × 240 × 65	4.3	DT 510 F	3242	325 × 265 × 195	G ½	560	140	0.7	5.15
500 × 300 × 65	9.5	DT 1028 F	3243	535 × 325 × 205	G ½	1280	320	1.4	9.65

*To achieve an improved efficiency, the ultrasound is modulated whereby in combination with SweepTec a four times higher value of the HF output is obtained as ultrasonic peak output.

The new generation: Ultrasonic bath SONOREX DIGITEC DT 1028 F combined with shaking device SA 1028

Ultrasonic bath DT 1028 F + shaking device SA 1028 = SONOSHAKE

Code No. 3257



SONOSHAKE offers a wide range of possible applications for sample preparation in many areas of analysis, for example, in environmental and foodstuffs analytics as well as in the area of medical diagnostics. The bath has a basic area of 500 mm x 300 mm and a tank depth of only 65 mm, making it ideal for sonication of samples in laboratory flasks.

The samples can be sonicated either for a selected period or in continuous mode. Quick degassing using the DEGAS function is also possible.

With four different shaking frequencies, the shaking device enables gentle to vigorous reciprocating motion up to a maximum of 20 mm. Both procedures can be carried out simultaneously or separately. This means that, for example, a sample can be pre-homogenized at a specified shaking frequency, and then final homogenization can be achieved in a very short time using ultrasound.

Shaking device SA 1028

- ➡ analogue setting of time (1 – 15 min or continuous) and shaking frequency
- ➡ reciprocating motion: settings in 4 steps possible of up to 200 rpm
- ➡ constant amplitude of 20 mm independently of loading
- ➡ rack easy to remove
- ➡ easy mounting of the laboratory clamps EK 10 –250 (ordering separately)
- ➡ shaking platform approx. 410 x 280 mm (l x w)
- ➡ mounting of 36 x 10-ml-flasks or 36 x 25-ml-flasks or 18 x 50-ml-flasks or 12 x 100-ml-flasks or 10 x 250-ml-Kolben
- ➡ required floor space of SONOSHAKE approx. 850 x 360 mm (l x w)



The shaking device SA 1028 can also be added to existing SONOREX DIGITEC DT 1028 F ultrasonic baths.

Code No. 3249

SA 1028

Ultrasonic special device for gentle removing of biofilm

Fast microbiological diagnostic method for implant-associated infections

The successful treatment of implant infections depends on an accurate microbiological diagnosis. Microorganisms form biofilms on implant surfaces, what makes them difficult to detect by conventional methods.

BactoSonic® gently removes biofilms from implant surfaces.

After sonication the liquid is cultured on agar plates and can be used for further analysis (e.g. microcalorimetry).

Fast diagnosis of infections is possible.



BT 5 with 2 IB 5

BS 14

Principle of BactoSonic®

The implants are placed in the air-tight implant boxes and sonicated in the specially designed ultrasonic device

BactoSonic®. Compared to other ultrasonic baths, BactoSonic® works with a very low ultrasound intensity.

The biofilm is removed without killing the bacteria, a quantitative assessment is possible.



Assessment of biofilm-forming bacteria on implants by BactoSonic®

The sonicated liquid is cultured and the quantity of bacteria can be determined. Compared to standard methods (e. g. biopsies from periprosthetic tissue) up to 10,000 times more bacteria can be detected. Mixed infections and different bacteria morphotypes can better be identified. The sensitivity especially of patients with previous antibiotic therapy is improved.

BactoSonic 14.2

Code No. 3290

Ready-to-use set consisting of:

Ultrasonic special device BS 14, with scientifically tested procedure, wire frame for foil test FT 14, TICKOPUR TR 3 (contact liquid - concentrate) - 250 ml

Implant boxes

IB 5, PP, 0,52 l - 2 pcs
IB 6, PP, 0,6 l - 2 pcs
IB 10, PP, 1,0 l - 1 pcs
IB 18, PP, 1,8 l - 1 pcs
IB 20, PP, 2,0 l - 1 pcs

Dimensions mm (x w x h)

145 x 110 x 67
dia. 142 x 68
278 x 115 x 60
208 x 143 x 94
135 x 102 x 282

Box trays for implant boxes

BT 5, PC, for 2 pcs IB 5
BT 6, PC, for 2 pcs IB 6
BT 10, PC, for 1 pcs IB 10
BT 18, PC, for 1 pcs IB 18
GH 14, stainless steel, for 3 pcs IB 20

PP = Polypropylen (plasma sterilisable), PC = Polycarbonat (plasma sterilisable)

Implant boxes vor ordering seperately:

Typ	Pkg Qty (pieces)	Code No.
IB 5	5	3280
IB 6	5	3281
IB 10	5	3282
IB 18	5	3283
IB 20	5	3284



Technical data

Inner tank dimensions, stainless steel: 325 x 300 x 150 mm l x w x d)
Filling volume for operation: 9,5 Liter (contact liquid)
Exterior dimensions: 355 x 325 x 305 mm (l x w x h)
Drain: ball valve G ½, left side
Timer: 1-15 min and ∞
Power selection switch: adjustable 20, 40, 60 80 and 100 %

HF output: max. 200 W_{eff} **
Frequency: 40 kHz
Current consumption: 1,0 A
Mains connection: 230 V~, 50/60 Hz
Weight with accessories: 14,0 kg

**Exceptionally homogeneous sound field with low intensity for a constant and gentle sonification.

Ultrasonic device with cooling for use in pathology and analysis laboratories

Decalcification of bone tissue in pathology

Decalcifying of bone tissue is an important step of histological preparation of samples (e.g. in oncology). Only decalcified samples can be used artefact-free for followed diagnosis. Compared to standard methods, the processing time is extremely shortened.

- no destroying of the morphologic structure of samples
- quantity of aggressive decalcifying liquids is reduced
- faster results of diagnosis

Use in analysis laboratories

With SONOCOOL® the catalytic effect of ultrasound can also be used when sonicating temperature-sensitive samples.

Exotherm reactions are possible because of the integrated cooling system, processes are faster and more effective.



SC 255



SONOCOOL 255

Code No. 3500

Consisting of:

Ultrasonic device, sample holder PH 255, for 8 inset beakers, lid D 255 G, 10 inset beakers SD 01 à 100 ml, TICKOPUR TR 3 (concentrate for producing the contact liquid) - 250 ml

Vorteile

- compact design
- increased life span by welded tank: stainless steel AISI 316Ti, 2 mm thick
- lid made of glass for easy cleaning and sample observation
- level sensor for contact liquid as dry run protection
- lighted LCD display for remaining time – actual temperature – pause/diagnostics – set time/set temperature – ultrasonic power
- serial interface for remote control

Technical data

Inner tank dimensions:	280 × 150 × 150 mm (l × w × d)
Tank volume:	5 litres (contact liquid)
Adjustable bath temperature:	15 – 30 °C (at 20 °C room temperature)
Cooling power:	200 W
Ultrasonic power:	180 W, adjustable in 4 steps
Ultrasonic frequency:	35 kHz, SweepTec®
Countdown operation:	up to 100 h
External dimensions:	360 × 605 × 385 mm (l × w × d)
Housing:	aluminium: coated with flush pulls (grips recessed inside the housing)
Outlet:	front left, concealed
Current consumption:	1.6 A
Mains connection:	230 V~, 50/60 Hz
Weight:	27.5 kg

Accessories

Sample holder PH 255

for 8 inset beakers SD 01

Code No. 3511



Inset beaker SD 01

100 ml, with ring
(package à 10 pieces)

Code No. 3516



SONOPULS Features

AMPLICHRON®-system

guarantees a constant amplitude independently from changing conditions within the sample. It ensures reproducible results for process validation. Settings within a range of 10 to 100 % are possible. Verification of actual value at the display. Permanent control of ultrasound irradiation as well as indication of wear of the probe.

Pulsation

limits temperature increase when processing heat-sensitive samples. The adjustable pulsation allows cooling during rest intervals.

Continuous operation

Constant sound radiation – extremely effective.

Built-in timer

Process duration storable. Indication of elapsed time in continuous operation or of remaining time in countdown mode.

Switching ON / OFF - easy to handle

either at the generator or directly at the ultrasonic converter via button or remote control.

Accessories

A wide range of probes and special accessories for a vast variety of applications.

Foil keypad

easy to clean and user-friendly.

ROHS compliant

Devices are built lead free.

Fail-safe during continuous operation and idling

CE-marked, also as medical device compliant to the directive for in-vitro diagnostics 98/79/EG

Features	mini20	HD 2000 series	HD 3000 series
Sample volume	0,1 – 25 ml	1 – 1000 ml	1 – 2500 ml
Amplitude control	10 – 100 %	10 – 100 %	10 – 100 %
Power control	yes (HF power)	no	yes (HF power)
Automatic amplitude limiting	yes	no	yes, after preselection of probe
Pulsation	ON cycles 0,1–60 s OFF cycles 0,2–60 s	10–100 % – storable (duty cycle, base 1 sec)	ON cycles 0,2–600 s OFF cycles 0,3–600 s
Time modes	50 min: 59 s	99 min: 59 s continuous or timed	9 h: 59 min: 59 s continuous or timed
Safety shut down	50 min: 59 s	no	9 h: 59 min: 59 s
Display	grafic / alphanumeric liquid crystal display of amplitude, pulsation mode, time, energy	numerical seven-segment display of amplitude, pulsation mode and time	grafic / alphanumeric liquid crystal display of amplitude, pulsation mode, time, energy and optionally temperature
Menu guided	comfortable setting of all values through „push & turn“	no	comfortable setting of all values through „push & turn“
Energy monitoring	in kJ	no	in kJ
Temperature monitoring and measurement	no	no	optional, 0–120 °C, temperature probe necessary, optional signal tone or switch - off
User programs	9	1	9, with software WINPULS®: 99
Remote control with PC	RS 232 (infrared)	no	RS 232 (infrared)
PC-Software, optionally available	no	no	WINPULS®
Error diagnosis	yes	no	yes
Processing frequency	30 kHz	20 kHz	20 kHz
Automatic storage of the last adjusted values	yes	no	yes
Operating test	yes	no	yes
Remote control	no	foot switch	foot switch

How to select the proper unit

Power output in watt is not the sole criterion for selecting an ultrasonic homogenizer. This value only indicates the power of the HF-generator but not the energy delivered to the sample. The amplitude at the radiating surface of the probe is the determining factor for the evaluation of the irradiation result while taking into consideration the volume of the sample.

HF generator:

Transforming of low-frequency voltage of 50 Hz into high-frequency voltage of 20 kHz.

Ultrasonic converter:

Transforming of electrical energy delivered from the generator into mechanical vibrations of 20 kHz.

Standard and booster horns:

Increasing of amplitude by their specially designed shape. The external thread is made for close connection of vessels.

Probes:

Transmitting of ultrasonic energy into the sample. Microtips, tapered and flat tips, dia. 2, 3, 6, 13, 19 and 25 mm, for use in different volumes.



Operating panel HD 2070 / HD 2200

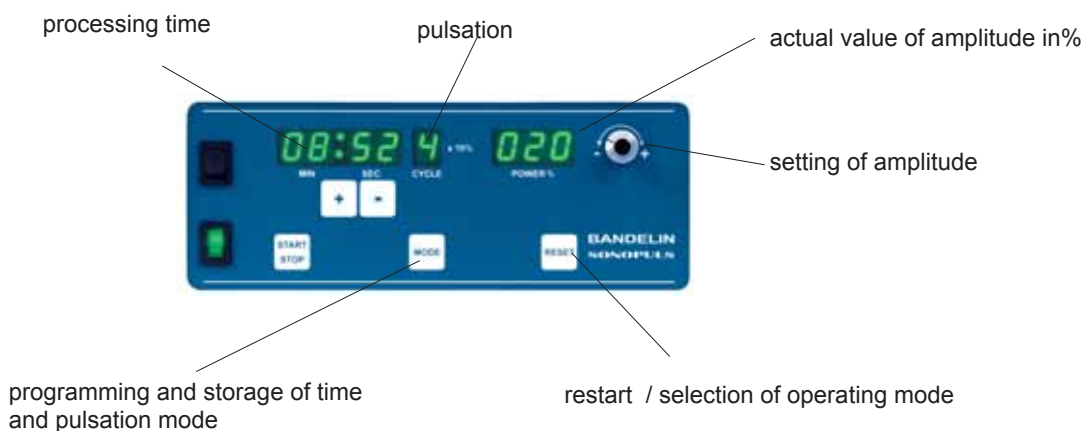

Operating panel HD 3100 / HD 3200 / HD 3400

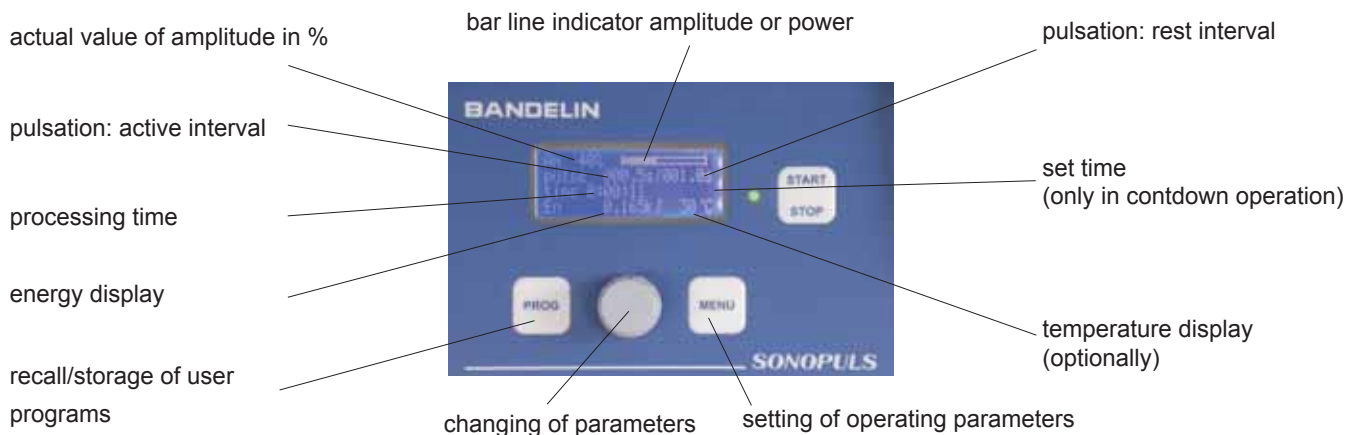

SONOPULS Ultrasonic homogenizers

SONOPULS mini20

for volumes up to 25 ml

Fast hand operation

Ready-to-operate for volumes from 0.5 ml to 25 ml, consisting of: HF generator mini20, ultrasonic converter mini20 and microtip MS 2.5, diameter 2.5 mm. Max. 12 W_{eff} HF output.

Code No. 3665



Fast manual use – ideal for smallest volumes. Pulsation on pressing the bottom at the ultrasonic converter by thumb.



HF generator		GM mini20
dimensions	mm	250 × 256 × 154
weight	kg	2.0
mains supply		230 V~, 50/60 Hz (optionally 115 V~, 50/60 Hz)
converter		UW mini20
dimensions	mm	dia. ca. 50 × 160
weight	g	270
available titanium probes	dia. mm	1.5 or 2.5

SONOPULS HD 2070

for volumes up to 200 ml

Small unit for lab routine

Ready-to-operate basic equipment for volumes from 2 ml to 50 ml consisting of: HF generator GM 2070, ultrasonic converter UW 2070, standard horn SH 70 G and microtip MS 73, 3 mm diameter. HF output max. 70 W_{eff}

Code No. 2450



SONOPULS HD 2200

for volumes up to 1000 ml

Standard unit for lab routine

Ready-to-operate basic equipment for volumes from 20 ml to 900 ml consisting of: HF generator GM 2200, ultrasonic converter UW 2200, booster horn SH 213 G and titanium flat tip TT 13 of 13 mm diameter. HF output max. 200 W_{eff}

Code No. 2530



HF generator		GM 2070	GM 2200
dimensions	mm	257 x 180 x 115	257 x 180 x 115
weight	kg	2.5	2.5
mains supply		230 V~, 50/60 Hz, optionally with voltage selector for 115 V~, 50/60 Hz	
converter		UW 2070	UW 2200
dimensions	mm	Ø 70 x 120	dia. 70 x 120
weight	kg	1.0	1.0
available titanium probes	dia. mm	2, 3, 6, 13	2, 3, 6, 13, 19 or 25

SONOPULS Ultrasonic homogenizers

SONOPULS HD 3100

for volumes up to 200 ml

High-Tech for research

Ready-to-operate for volumes from 2 ml to 50 ml, consisting of:
HF generator GM 3100,
ultrasonic converter UW 3100,
standard horn SH 70 G and microtip MS 73 diameter 3 mm.
Max. 100 W_{eff} HF output.

Code No. 3680



SONOPULS HD 3200

for volumes up to 1000 ml

High-Tech for reserch

Ready-to-operate for volumes from 20 ml to 900 ml, consisting of:
HF generator GM 3200, ultrasonic converter UW 3200,
booster horn SH 213 G and flat tip TT 13, diameter 13 mm.
Max. 200 W_{eff} HF output.

Code No. 3660



HF generator		GM 3100	GM 3200
dimensions	mm	250 x 256 x 154	250 x 256 x 170
weight	kg	2.0	2.7
mains supply		230 V~, 50/60 Hz, optionally 115 V~, 50/60 Hz	
converter		UW 3100	UW 3200
dimensions	mm	dia. 70 x 120	dia. 70 x 120
weight	kg	1.0	1.0
available titanium probes	dia. mm	2, 3, 6 or 13	2, 3, 6, 13, 19 or 25

SONOPULS HD 3400

for volumes up to 2500 ml

High-Tech for reserch and pilot plant stations

Ready-to-operate for volumes from 100 ml to 2500 ml, consisting of:
HF generator GM 3400,
ultrasonic converter UW 3400,
booster horn SH 3425 and
extended probe VS 200 T, diameter 25 mm.
Max. 400 W_{eff} HF output.

Code No. 3690



HF generator		GM 3400
dimensions	mm	324 x 230 x 131
weight	kg	3.1
mains supply		230 V~, 50/60 Hz
converter		UW 3400
dimensions	mm	dia. 90 x 180
weight	kg	2.2
available titanium probes	dia. mm	19 or 25

SONOPULS Applications

Ultrasonic homogenizers are used in laboratories, hospitals and in industry for scientific experiments and analysis as well as in pilot or small lot production. Here are some examples showing the vast variety of applications for ultrasonic homogenizers:

Typical areas of application

- ⇒ Disruption of cells, bacteria, virus, tissue, also mixed tissue
e. g. for extraction of cell contents
- ⇒ Emulsifying of hardly mixable liquids, e.g. oil and water, particle size in μm range
- ⇒ Deagglomeration of nanoparticles in material research (nanostructured material) in medicine, biotechnology, automobile industry
- ⇒ Acceleration of chemical reactions
- ⇒ Production of dispersions



Analysis

- ⇒ Preparing samples for grain size determination or environmental analysis:
HD 3200 or **HD 2200** with tapered tip **KE 76** or with extended probe **VS 70 T**.
- ⇒ Homogenizing of cheese samples for determination of nitrates:
HD 3200 or **HD 2200** with **MS 73**



Biochemistry - Biology - Medicine

- ⇒ Sonication of small high-quality samples for analysis like EIA or RIA:
HD 3100 and **HD 2070** with microtip **MS 72** or **MS 73**.
- ⇒ Due to high amplitudes, disruption of high-resistant bacteria, cells or tissues is possible. Indirect processing of sample in cup booster **BR 30** or in cup horns **BB 2 G** or **BB 6** is recommended to avoid cross-contamination.
- ⇒ Detection of prions by cyclic amplification of protein misfolding:
HD 2070 with **MS 73**
- ⇒ Simultaneous sonication of 12 samples in microplates:
HD 3100 with **MR 12-2**



Chemistry and Sonochemistry

- ⇒ Acceleration of chemical reactions or destroying of highly-molecular compounds:
HD 3200 or **HD 2200** with tapered tip **KE 76** and sleeve adapters **NA 29 G** or **NA 45 G** for tight fitting to a sonochemical reaction vessel.

Pharmacy - Cosmetic

- ⇒ Production of larger volumes of long lasting emulsions, e. g. lotions and production of antigens, vaccines or liposomes:
HD 3200 or **HD 2200** with flow-through cell **DG 4 G**

For special customer requests: BANDELIN will supply booster horns and probes for special applications.

Waste water samples

Aim: Homogenizing for determination of harmful substances, e.g. mineral oil, grease AOX in industrial and butcher's waste water

Quantity: 250 ml

Approx.time: 5 - 10 min

Unit: HD 2200/3200 with TT 13, or taller vessels with VS 70 T

Aluminium oxide suspensions

Aim: Dispersing

Quantity: 100 ml

Approx.time: ca. 4 min

Unit: HD 3200 with KE 76

Soil samples

Aim: Extraction for determination of pH value, Mg, K, P, N – contents for recommendation of fertilizer / determination of radio nucleides to control radioactivity in the environment (milk research)

Quantity: 50 - 100 ml / 100 - 150 ml

Approx.time: a few seconds

Unit: HD 2200/3200 with KE 76 / VS 70 T

Bladder tissue

Aim: Disruption

Quantity: 1,5 ml

Approx.time: ca. 1,5 min

Unit: HD 2200 with MS 72, cooling necessary

Candida albicans

Aim: Disruption

Quantity: 10 ml

Approx.time: ca. 10 min

Unit: HD 2070/3100 with MS 73

ChIP (Chromatin immunoprecipitation)

Aim: DNA fragmentation

Quantity: 1 ml

Approx.time: ca. 2 min

Unit: HD 3200 with MS 72

Large intestine tissue

Aim: Disruption

Quantity: 1,5 ml

Approx.time: ca. 3 min

Unit: HD 2200 with MS 72, cooling necessary

Dispersing of solid particles

Aim: granulometric measurement

Quantity: 50 - 100 ml

Approx.time: ca. 2 - 5 min

Unit: HD 2200/3200 with KE 76

Small intestine tissue

Aim: Disruption

Quantity: 1,5 ml

Approx.time: ca. 2,5 min

Unit: HD 2200 with MS 72, cooling necessary

Escherichia coli

Aim: Disruption for proteine lay off

Quantity: 10 ml

Approx.time: ca. 5 - 10 min

Unit: HD 2070/3100 with MS 73 or HD 2200 with MS 73

Eucaryotic cells

Aim: Disruption for proteine lay off

Quantity: 1,5 ml

Approx.time: ca. 1 min

Unit: HD 2200/3200 with BR 30 u. EH 3, cooling necessary

Meat and sausage samples

Aim: Homogenizing for determination of nitrates

Quantity: 100 ml

Approx.time: ca. 3 min

Unit: HD 2200/3200 with KE 76

Heart muscle tissue

Aim: Homogenizing

Quantity: 1,5 ml

Approx.time: ca. 4 min

Unit: HD 2200/3200 with MS 72, cooling necessary

Brain tissue

Aim: Disruption

Quantity: 1,5 ml

Approx.time: ca. 1 min

Unit: HD 2200 with MS 72, cooling necessary

Yeast cells

Aim: Disruption

Quantity: 10 ml

Approx.time: ca. 2 min

Unit: HD 3200 with MS 73

Insect cells

Aim: Disruption for proteine lay off

Quantity: 20 - 50 ml

Approx.time: ca. 25 sec, pulsed

Unit: HD 2070/3100 with MS 73 and RZ 2

Liver tissue

Aim: Homogenizing for molecular genetic tests

Quantity: 1,5 ml

Approx.time: ca. 1½ min

Unit: HD 2200/3200 with MS 72, cooling necessary

Liposomes

Aim: Producing of small unilamellar phospholipid vesicles

Quantity: 20 ml

Approx.time: ca. 10 - 15 min

Unit: HD 2070/3100 with TT 13,

cooling necessary

Lymphocytes

Aim: Disruption

Quantity: 50 µl - 2 ml

Approx.time: ca. 1 - 5 min

Unit: HD 2070/3100 with BR 30 and EH 3

Nano emulsions

Aim: Drop sizes within nm range

Quantity: 2 ml

Approx.time: ca. 5 min

Unit: HD 3100 with MS 72,

cooling necessary

Nano particles

Aim: Dispersing

Quantity: 100 ml

Approx.time: ca. 2 min

Unit: HD 3200 with KE 76

Retina

Aim: Tissue disruption

Quantity: 60 ml

Approx.time: 15 short stokes

Unit: mini20 with MS 2.5

Kidney tissue

Aim: Homogenizing

Quantity: 1,5 ml

Approx.time: ca. 40 sec

Unit: HD 2200/3200 with MS 72,

cooling necessary

O/W emulsions

Aim: Finest emulsions

Quantity: 10 ml

Approx.time: ca. 1 min

Unit: HD 3200 with KE 76,

Vessel: rosett cell

Homogenizing of aqueous ink

Aim: Dispersing of ink pigments in oil

Quantity: 200 ml

Approx.time: ca. 5 min

Unit: HD 2200 with VS 70 T

Carbon black dispersions

Aim: Homogenizing

Quantity: 50 ml

Approx.time: ca. 5 min

Unit: HD 2200 with DH 13 G, vessel: KG 3

Accessories and applications

HD 2070 HD 3100

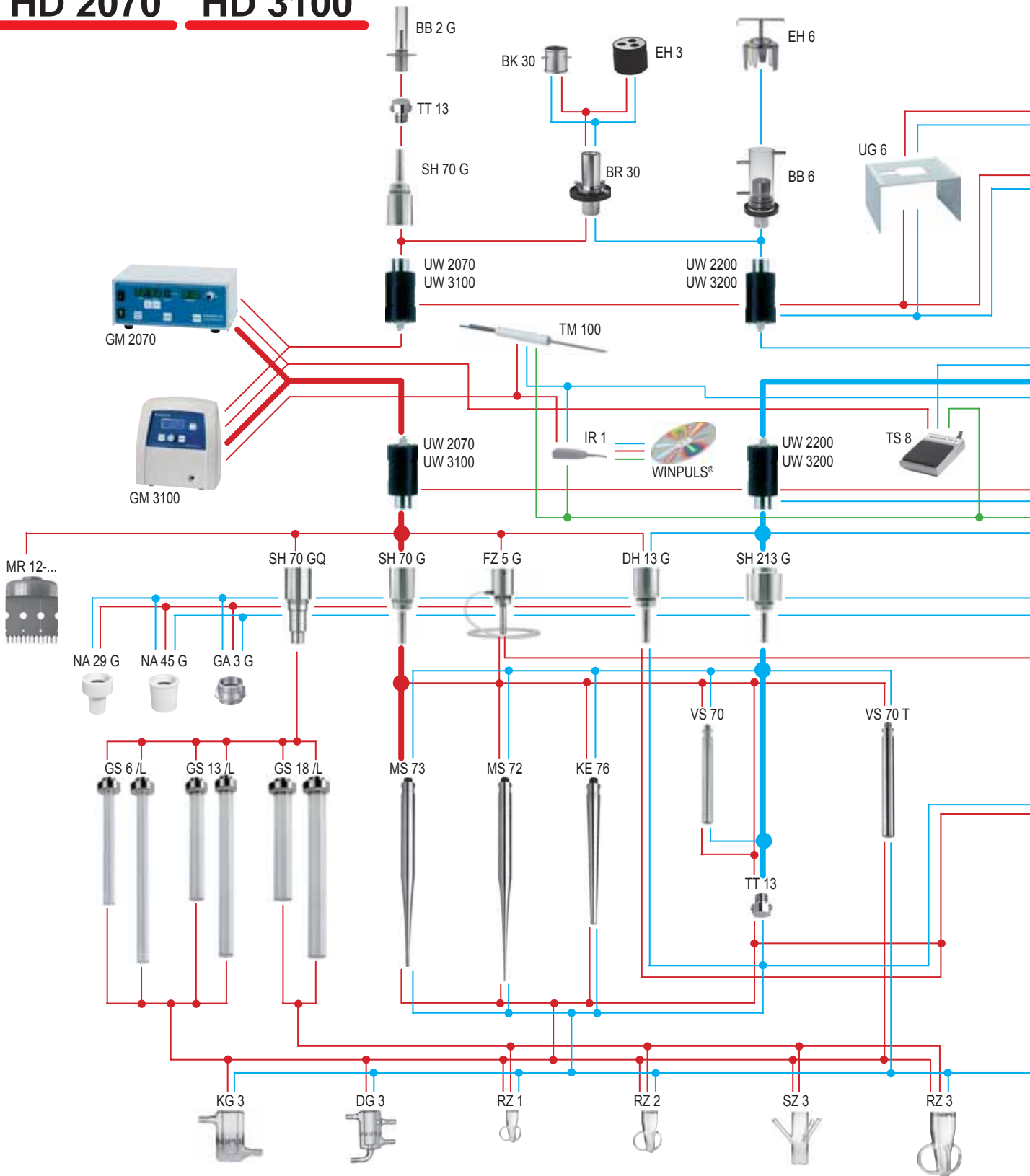

Saccharomyces cerevisiae

Aim: Disruption

Quantity: 20 ml

Approx time: 15 min

Unit: HD 2200/3200 with KE 76, addition of glass beads to accelerate process, cooling necessary

Staphylococcus aureus

Aim: Disruption

Quantity: 10 ml

Approx time: ca. 10 min

Unit: HD 2070/3100 with MS 73

Accessories and applications

HD 2200

HD 3200

HD 3400

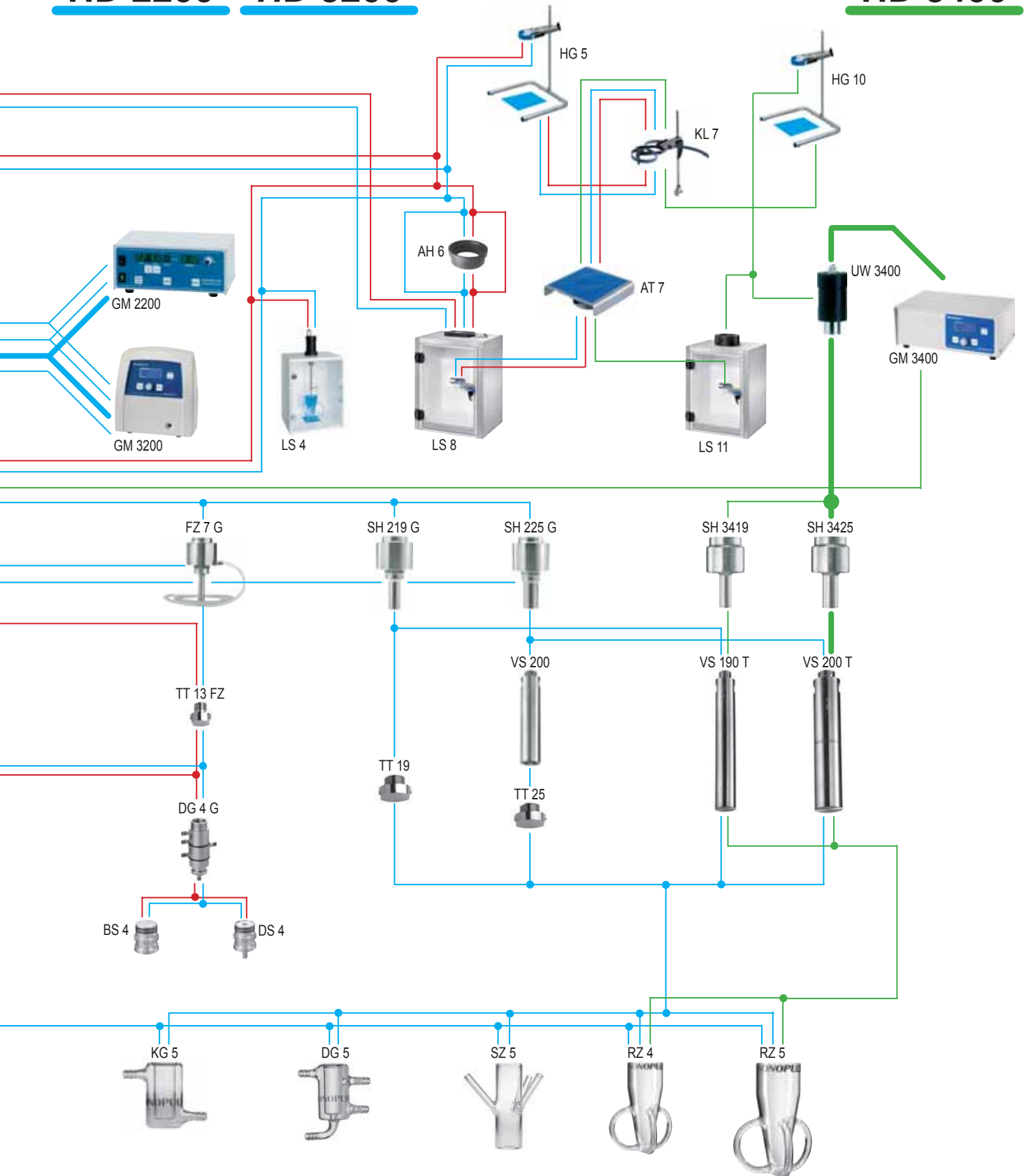

Streptococcus

Aim: Disruption
Quantity: 10 ml
Approx time: ca. 8 - 10 min
Unit: HD 2200/3200 with MS 73

Detection of prions by cyclic amplification of protein misfolding

Quantity: 200 µl
Approx time: ca. 1,5 min
Unit: HD 2070 with MS 73

Probes • Standard and booster horns • Adapters

Probes

made of titanium alloy (Ti-Al6-V4) transmit mechanical longitudinal waves into the sample. They are thermo-resistant, can be treated in autoclaves and are resistant to corrosive media. Sample volume, diameter of the processing vessel and the required amplitude determine the selection of the unit and the type of probe.

The higher the amplitude, the more intense the sonication.

Please note that probes are subject to wear and tear.

It is advisable to order spare probes with the homogenizer.



MS 1.5 MS 2.5

MS 72 MS 73 KE 76 VS 70T VS 190T VS 200T TT 13 TT 19 TT 25

description		microtips				tapered tip	extended probes			
Type		MS 1.5	MS 2.5	MS 72	MS 73	KE 76	VS 70 T	VS 190 T	VS 200 T	
Code No.		3639	3652	492	529	530	494	3638	478	
Diameter	mm	1,5	2,5	2	3	6	13	19	25	
Length approx	mm	57	53	191	175	135	130	130	130	
Standard horn for HD 2070/3100		-	-	SH 70 G	SH 70 G	SH 70 G	SH 70 G	-	-	
Booster horn for HD 2200/3200		-	-	SH 213 G	SH 213 G	SH 213 G	SH 213 G	SH 219 G	SH 225 G	
Booster horn for HD 3400		-	-	-	-	-	-	SH 3419	SH 3425	
Amplitude for HD 2070/3100	μm_{SS}	-	-	253 / 285	212 / 245	165 / 191	80 / 97	-	- / -	
Amplitude for HD 2200/3200	(peak to peak)	-	-	282 / 286	302 / 308	249 / 255	153 / 170	-	46 / 51	
Amplitude for HD 3400		-	-	-	-	-	-	116	82	
Amplitude for mini20		50	70	-	-	-	-	-	-	
Volume HD 2070/3100	ml	-	-	1–25	2–50	5–100	10–200	-	-	
Volume HD 2200/3200	ml	-	-	2–30	5–90	10–350	20–900	25–900	30–1000	
Volume HD 3400	ml	-	-	-	-	-	-	500–1500	500–2500	
Volume mini20	ml	0,1–10	0,5–25	-	-	-	-	-	-	
Vessel diameter (minimum)	mm	4	6	4	6	8	17	23	29	

Probe length may vary slightly due to the variations in the titanium material.

Standard and booster horns

(Ti-Al6-V4) are furnished with a thread for replaceable probes. With exterior thread (except SH 3419, SH 3425) to connect various vessels.

Solid standard horn - DH 13 G -
with diamond coating on the radiating surface;
lifetime is thirty times longer than usual.



SH 70 G SH 213 G SH 219 G SH 225 G SH 3419 SH 3425 DH 13 G

Flow-through standard and booster horns

material: Ti-6Al-4V, to prepare stable mixtures of non-mixable or hardly mixable liquids (oil-in-water) by direct intrusion of pre-mixed samples into the cavitation field. In combination with flow-through cell DG 4 G, the continuous treatment of 2 different media and parallel tempering is possible.



FZ 5 G

FZ 7 G

	standard horn	booster horns					diamond standard horn	flow-through standard horn	flow-through booster horn
Type	SH 70 G	SH 213 G	SH 219 G	SH 225 G	SH 3419	SH 3425	DH 13 G	FZ 5 G	FZ 7 G
for HD	2070 / 3100	2200 / 3200			3400		2070 / 2200 3100 / 3200	2070 / 3100	2200 / 3200
Code No.	486	527	3647	3634	3679	3692	403	490	452

Adapters

Sleeve adapters made of PTFE for tight mounting on standard ground glass vessels.

NA 29 G for NS 29/32 for SH 70/213 G

NA 45 G for NS 45/40 for SH 70/213/219/225G

Threaded adapter made of stainless steel with external thread M 40 x 1

GA 3 G for SH 70/213/219/225 G



NA 29 G NA 45 G

GA 3 G

	sleeve adapters		threaded adapter
Type	NA 29 G	NA 45 G	GA 3 G
for HD	2070 / 2200 / 3100 / 3200		
Code No.	540	487	473

Probe extensions

for enlarging the operating depth when using flat tips.

VS 70 between SH 70 G / 213 G and TT 13

VS 200 between SH 225 G and TT 25



	probe extensions	
Type	VS 70	VS 200
for HD	2070 / 2200 3100 / 3200	2200 / 3200
Code No.	500	415

titanium flat tips			silica glass probes					
TT 13	TT 19	TT 25	GS 6	GS 6 L	GS 13	GS 13 L	GS 18	GS 18 L
497	491	532	024	048	028	050	040	054
13	19	25	6		13		18	
5	5	6	145	290	145	290	145	290
SH 70 G	-	-	SH 70 GQ		SH 70 GQ		SH 70 GQ	
SH 213 G	SH 219 G	SH 225 G	-		-		-	
-	-	-	-		-		-	
78 / 93	- / -	- / -	13 / 13		13 / 13		13 / 13	
149 / 165	73 / 81	48 / 53	- / -		- / -		- / -	
-	-	-	- / -		- / -		- / -	
-	-	-	- / -		- / -		- / -	
10-200	-	-	2-100		25-200		25-500	
20-900	25-900	30-1000	-		-		-	
-	-	-	-		-		-	
-	-	-	-		-		-	
17	23	29	10		17		22	

Silica glass probes

for connection to HD 2070/3100 with special horn SH 70 GQ.

For application in food analysis, pharmacy or environmental analysis. No intrusion of metal particles and boron compounds - ideal for trace analysis. High chemical and temperature shock resistance, no electric conductivity.



MULTISON® ultrasonic probe

patent applied D 10 2004 024 214

for connection to HD 2070/3100.

Composed of Multison horn MRH 12 and 12 Multison tips MRS 2, MRS 3 or MRS 2-2C .
For irradiation of samples in microplates and deep well plates.

Simultaneous sonication of 12 samples.
Multison tips individually replaceable.



	Multison probe composed of multison horn with per 1 multison tip			multison tips		
Type	MR 12-2	MR 12-2C	MR 12-3	MRS 2	MRS 3	MRS-2C
Diameter, mm	2	2	3	2	3	2
Length, mm	16					
Code No.	3626	3643	3633	3628	3629	3642

Processing vessel, made of stainless steel

DG 4 G for high-volume flow-through processing like emulsifying, dispersing or homogenizing, up to 30 l/h. The sample can be repeatedly sonicated in circulation. For connection to SH 70 G or SH 213 G with TT 13, DH 13 G.



DG 4 G

KG 4 G, closed vessel with cooling jacket. Processing volume about 65 ml.

	flow-through processing vessel	cooling vessel
Type	DG 4 G	KG 4 G
for HD	2070 / 2200 3100 / 3200	2070 / 2200
Code No.	3608	3608

Processing vessels made of glass

Cooling vessel KG

for sonication of temperature-sensitive samples. The cooling jacket allows circulation of cooling liquid during sonication.

Flow-through vessel DG

with cooling jacket for irradiation of larger volumes. The cooling jacket allows circulation of cooling liquid during sonication.

Rosett cell RZ

for homogenous and intense circulation of liquids caused by the shape of the vessel and its 3 sidearms

Suslick cell SZ

with 3 sidearms for introduction of gas or measuring probes.



KG 3



DG 3



RZ 3



SZ 3

Type	cooling vessels		flow-through vessels		rosett cells					suslick cells	
	KG 3	KG 5	DG 3	DG 5	RZ 1	RZ 2	RZ 3	RZ 4	RZ 5	SZ 3	SZ 5
for HD	2070 / 2200 3100 / 3200	2200 3200	2070 / 2200 3100 / 3200	2070 / 2200	2070 / 2200 / 3100 / 3200			2200 / 3200 3400		2070 3100	2200 3200
volume, ml	15	70	max. 5,6 l/h	max. 30 l/h	25	40	110	390	660	20	110
interior diameter, mm	20	35	20	53	30	42	50	75	90	20	40
height, mm	65	95	65	95	85	100	135	202	243	80	144
Code No.	536	481	538	482	3606	3607	522	3256	483	534	484

Processing vessels for indirect processing



EH 6

BB 6

BB 2 G

+ SH 70 G + TT 13

Type	BB 6	BB 2 G	EH 6	BR 30	BK 30	EH 3
for HD	2200 / 3200	2070 / 3100	2200 / 3200	2070 / 2200 3100 / 3200	BR 30	BR 30
Code No.	3605	552	059	082	098	078

Microtube holder EH 6

For use in BB 6. Up to 6 samples can be treated simultaneously. Pressure plate holds tubes in place. No floating of cups. A mixing of samples is excluded due to markings at the holder.

Cup horn BB 6

for indirect intense sonication. The cup horn is equipped with inlet and outlet for circulation of cooling liquid. Also useable for direct sonication.

Cup horn BB 2 G

plastics, for indirect sonication of pathogenic material.

Microtube holder EH 3

for use with BR 30. Up to 3 samples can be treated simultaneously. 2 exchangeable discs with hole diameters 8,5 or 11,5 mm.

Inset basket BK 30

For intensive cleaning of small parts, e. g. cleaning of radioactively contaminated seeds in BR 30.

Cup booster BR 30

For high-intensive irradiation of smallest and sensitive sample volumes, e. g. radioactive seeds or bacteria as well as for flow-through sonication of liquids like cell suspensions. During indirect processing of samples the ultrasound will be transferred by the contact liquid. The sonication will be carried out in reaction vessels or in the inset beaker BK 30. The cup booster is equipped with inlet, outlet and overflow. Either cooling or flow-through processing are possible.

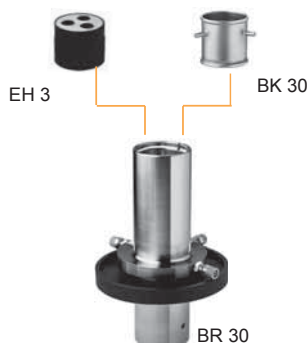

EH 3

BK 30

BR 30

Stand

Stainless steel stand

with lab clamp and non-slip mat to hold processing vessels securely in place

Clamping device KL 7 (DE 20 2006 005 654.98)

for HG 5 / HG 10 with rod and swivelling clamp for reaction vessels
dia. 15 mm to dia. 100 mm

Supporting table AT 7

suitable for KL 7 or in LS 8
with non-slip mat to hold
sample vessels securely
in place

Type	HG 5	HG 10	KL 7	AT 7
for HD	2070 / 2200 3100 / 3200	3400	HG 5 HG 10	KL 7 LS 8
Code No.	459	3646	3636	3644



Sound proof boxes

reduce the noise level considerably. Precut holes at the backside allow connections for gas supply and flow-through processing. Acrylic door permits process monitoring.

LS 4 Plastic coated walls, 10 dB-AU damping.

LS 8 made of stainless steel, with damping material. 20 dB-AU damping.

The damping material is water resistant – easy cleaning.

With rod, swivelling clamp and clamp for height adjustment of sample vessels.

Clamping belt for safe fixing of sample vessels with different sizes. Also applicable for sonication of samples in glass vessels with round bottoms or with inlets from below.

Special support UG 6 is available for inverted position of the box during indirect sonication with cup horn BB 6 or cup booster BR 30. Ultrasonic converter is fixed safely through a special clamp.

LS 11 made of stainless steel with damping material, 20 dB-AU damping. The damping material is water resistant, easy cleaning. **Distance tube** for direct processing with long probes

AH 6: for MS 72/73, KE 76, VS 70 with TT 13, VS 200 mit TT 25 / VS 200 T, VS 70 T, GS ...

BD 8: damping material for sound proof boxes



Type	LS 4	LS 8	LS 11	UG 6	AH 6	BD 8
for HD	2070 / 2200 3100 / 3200	2070 / 2200 3100 / 3200	3400	2070 / 2200 3100 / 3200	LS 8	LS 8 LS 11
dB-AU damping	10	20	20	-	-	-
Code No.	416	3653	3663	3616	3619	3661

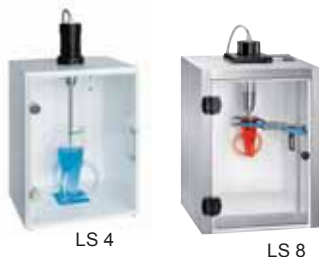

WINPULS® remote control

For process control with PC for operation systems
MICROSOFT® WINDOWS® 2000 and
MICROSOFT® WINDOWS® XP.

With different additional functions like test logging and
comfortable data storage (up to 99 storages).

Set composed of WINPULS® software and
infrared adapter IR 1 for interface RS 232

Type	WINPULS® software with infrared adapter IR 1
for HD	3100 / 3200 / 3400
Code No.	3625



Foot switch remote control

for easy switching ON/OFF of the HF generator.
With 3 m cable.

Type	TS 8
for HD	2070 / 2200 3100 / 3200 / 3400
Code No.	531



Temperature sensor

for measuring the sample temperature
from 0 up to 120 °C.
Sensor diameter: 4 mm

Type	TM 100
for HD	3100 / 3200 / 3400
Code No.	3622



Wirbelreaktor VORTEX®

- ⇒ Intensifying of industrial, biotechnological and chemical processes
- ⇒ Degassing
- ⇒ Disrupting of bacteria
- ⇒ Disinfection of liquids
- ⇒ Producing of finest polishing pastes for wafer industry
- ⇒ Homogenizing

Vortex reactor
consisting of:
Vortex reactor WB and
HF generator LG 2002 T



WR 4-1503.01

Rohrreaktor SONOBLOC®

- ⇒ intensive treatment of fibrous and bandshaped products
- ⇒ Support of industrial and biotechnological processes
- ⇒ Wire cleaning
- ⇒ Degassing
- ⇒ Disrupting of bacteria
- ⇒ Acceleration of disintegration
- ⇒ Dispersing of solid particles in liquids

Tube reactor SONOBLOC®
consisting of:
Tube reactorbloc RB and
HF generator LG 1001 T



SB 8-1002.01

Technical Data	Vortex reactorbloc - WB			Tube reactorbloc - RB	
Type	WB 4-1402...	WB 4-1503...	WB 4-1604...	RB 8-1002...	RB 8-1004...
Flow-through rate	1 - 50 l/min			1 - 100 l/min	
Internal pressure, max.	10 bar			10 bar	
Solid particles	< 5 mm			-	
Power density, max.	480 W/l	520 W/l	550 W/l	500 W/l	
Power, max.	1400 W	1500 W	1600 W	1000 W	
Frequency	25 kHz	25 und 40 kHz	40 kHz	25 kHz	40 kHz
Tube material / dimensions	Stainless steel AISI 316 Ti / dia. 139.7 × 2.6 mm; dia. 104 × 2 mm			Stainless steel AISI 316 Ti / dia. 60.3 × 3.6 mm	
Housing dimensions (l × w × h)	290 × 290 × 642 mm			260 × 150 × 990 mm	
Weight, net	approx. 50 kg			approx. 35 kg	
HF generator (separate)	LG 1510 T	LG 2002 T		LG 1001 T	

Units are equipped with standard victaulic connection. Further connection versions on request.

Separate documentation on request.

SONOREX TECHNIK industrial ultrasonic units



RM 110 UH

SONOREX TECHNIK modular programme RM is available in 6 standard sizes with 4 versions for cleaning as well as for rinsing. Once the cleaning process is defined, the units can be matched individually:

RM ... UH cleaning unit with ultrasound and heating RM ... U cleaning unit with ultrasound
RM ... H rinsing unit with heating RM ... rinsing unit without ultrasound and heating

Frequency 40 kHz, starting with RM 110 UH alternatively 25 kHz. RM 16 UH to 75 UH, 230 V~, 50/60 Hz, RM 110 UH to 210 UH, 380 to 415 V, 3-phase current~, N, PE, 50/60 Hz, 16 A. Heating 30 to 80 °C (86 to 176 °F). Welded tank, 2 mm stainless steel AISI 316 Ti. Overflow, welded one-piece drain, drip-proof stainless steel housing and a sprinkle tube (from RM 110 UH upwards).

Internal tank dimensions (l x w x d) mm	Capacity litres	Type	Code No.	External dimensions (l x w x h) mm	Drain ball valve	HF output W _{eff}	Heating power W	Current consumption A**	Weight net kg
325 × 275 × 200	13,0	RM 16 UH	8200	365 × 340 × 390	G ½	1 × 300	800	4.8	16,0
480 × 300 × 300	30,0	RM 40 UH	8210	540 × 340 × 500	G ¾	1 × 500	1250	7.7	26,0
580 × 500 × 300	60,0	RM 75 UH	8220	640 × 540 × 530	G ¾	1 × 1000	1950	12.9	42,0
600 × 450 × 450	110,0	RM 110 UH	8230	780 × 550 × 800	G 1	1 × 1000	4800	10.5	72,0
1000 × 500 × 400	160,0	RM 180 UH	8250	1180 × 600 × 800	G 1	2 × 1000	7200	14.8	135,0
750 × 650 × 500	210,0	RM 210 UH	8270	930 × 750 × 800	G 1	2 × 1000	7200	14.8	110,0

**from RM 110 pro phase

Models RM 112 to 212 with round tank corners and oblique bottom. Models ZM 112 to 212 with a separate HF generator, multiple-frequency ultrasound at the bottom and at the side, specification like RM 112.

5772 e/2010-05

All units are CE marked.
Illustrations exemplarily, not to scale

Subject to technical alterations without notice.
Decoration products are not included in delivery.

The general delivery terms apply.